



PLANNING COMMISSION
Veronica Harvey – Chairperson
Ruben Rivera – Vice Chairperson
Alice Abatti – Commissioner
Rebecca Terrazas-Baxter – Commissioner
Lisa Winkler-Commissioner

AGENDA

PLANNING COMMISSION

220 West 9th Street
IMPERIAL, CA 92251

WEDNESDAY, JUNE 26, 2024
6:30 P.M.

The Imperial Planning Commission Meetings, including public comments, are being Livestreamed on the City's social media pages. If attending in person, by remaining in the room, you are giving your permission to be recorded.

1. You are encouraged to observe the City Council meetings via Livestream at the City of Imperial Facebook page.
2. If you are unable to participate in-person, and wish to address the City Council on matters within their jurisdiction, please email public comments to cityclerk@citofimperial.org
3. All documents containing an executive summary and staff recommendation associated with open session action items are made available for public inspection on the City's website, www.cityofimperial.org seventy-two (72) hours prior to the posted meeting time. Government Code Section 54957.5(b)(2)(B).

In compliance with the Americans With Disabilities Act, if you need special assistance to participate in this meeting, please contact (760) 355-4373. Notification 48 hours prior to the meeting will enable the city to make reasonable arrangements to ensure accessibility to this meeting [28cfr 35.102-35.104 ADA title ii]

A. PLANNING COMMISSION CONVENES TO OPEN SESSION AT 6:30 PM:

ROLL CALL
PLEDGE OF ALLEGIANCE
ADJUSTMENTS TO THE AGENDA

B. PUBLIC APPEARANCES

B-1. Matters not appearing on the agenda. If you wish to address the Planning Commission concerning any item not appearing on the agenda and within the Commission's jurisdiction, please raise your hand and be acknowledged by the Chairperson, and at that time state your name and address for the record. The Chairperson reserves the right to place a time limit on each person's presentation of three (3) minutes. It is requested that longer presentations be submitted to the Commission in writing.

C. SPECIAL PRESENTATION:

C-1 Recognition of service to former Planning Commissioner, Mark Hammerness.

D. CONSENT CALENDAR:

All items appearing under "Consent Agenda" will be acted upon by the Planning Commission in one motion without discussion. Should any Commissioner or other person request that any item be considered separately, that item will then be taken up at the time as determined by the Chairperson.

D-1. Approve Planning Commission Meeting Minutes for March 27, 2024

D-2. Approve Planning Commission Meeting Minutes for June 12, 2024

E. PUBLIC HEARING: (DISCUSSION/ACTION – RECOMMEND/DENY)

E-1: Subject: Continued Public Hearing, Discussion/Action: Variance 23-04 and Conditional Use Permit 23-07 for Mark Gaddis to allow the deviation of the Residential Zone Property Development Standards for maximum height and setback requirements for an accessory structure located at 121 North F Street (APN 064-042-0001). The project is categorically exempt from the California Environmental Quality Act (CEQA) under Section 15301, Existing Facilities.

- 1. Continued Public Hearing**
- 2. Staff Report – Public Comment**
- 3. Commission Discussion**
- 4. Close Public Hearing**
- 5. Recommended Action:** Approve/Deny Resolution No. PC2024-01: A RESOLUTION OF THE PLANNING COMMISSION, OF THE CITY OF IMPERIAL, DENYING APPROVAL OF VARIANCE 23-04 AND CONDITIONAL USE PERMIT 23-07 FOR MARK GADDIS TO ALLOW THE DEVIATION OF THE RESIDENTIAL ZONE’S PROPERTY DEVELOPMENT STANDARDS FOR MAXIMUM HEIGHT AND SETBACK REQUIREMENTS FOR AN ACCESSORY STRUCTURE LOCATED AT 121 NORTH F STREET (APN 064-042-001).

F. REPORTS:

F-1: Commissioners’ Reports

F-2 Staff Reports

G. ADJOURNMENT

G-1. Subject: Adjourn the Planning Commission meeting until the next regularly scheduled meeting on July 10, 2024 at 6:30pm.

NOTE: Any documents produced by the City and distributed to a majority of the Planning Commission regarding any item on this agenda will be made available at the front counter at City Hall, located at 420 South Imperial Avenue, during normal business hours.



PLANNING COMMISSION
Veronica Harvey – Chairperson
Ruben Rivera – Vice Chairperson
Alice Abatti – Commissioner
Rebecca Terrazas-Baxter – Commissioner
Lisa Winkler – Commissioner

MINUTES

PLANNING COMMISSION
TRAFFIC COMMISSION

220 West 9th Street
IMPERIAL, CA 92251

WEDNESDAY, MARCH 27, 2024
6:30 P.M.

A. PLANNING COMMISSION CONVENES TO OPEN SESSION AT 6:30 PM:

CALLED TO ORDER: Chairperson Harvey called the Meeting to Order at 6:33 p.m.

ROLL CALL: Commissioner Terrazas-Baxter, Vice Chairperson Rivera, Chairperson Harvey.

ABSENT: Commissioner Winkler, Commissioner Abatti

Commissioner Abatti arrived at 6:46 p.m.

PLEDGE OF ALLEGIANCE: The Pledge was led by Veronica Harvey.

ADJUSTMENTS TO THE AGENDA: None

B. PUBLIC APPEARANCES

B-1. Matters not appearing on the agenda.

None

C. SPECIAL PRESENTATION

C-1 David Ramirez, Code Enforcement Officer, made a presentation regarding the on Municipal Code Amendment to Chapter 14, Section 14-5, Declaration of Public Nuisance addressing palm tree growth.

D. PUBLIC HEARING: (DISCUSSION/ACTION-RECOMMEND/DENY):

D-1: Subject: Public Hearing, Discussion/Action: Variance 24-01 for Quentin Tucker to allow the deviation of the Commercial Zone's Property Development Standards for front yard and street-side setback requirements for project site located at 300 E. Barioni Blvd. (APN 064-063-001). The project is categorically exempt from the California Quality Act (CEQA) under Section 15332, In-Fill Developments.

The public hearing was opened at 7:04 p.m.

The staff report was presented by Yvonne Cordero City Planner.

The public hearing was closed at 7:13 p.m.

Moved by Abatti, seconded by Terrazas-Baxter to approve Variance 24-01.

AYES: Abatti, Terrazas-Baxter, Rivera and Harvey

NOES: None

ABSTAIN: Winkler

ABSENT: None

MOTION CARRIES: 4-0

D-2: Subject: Public Hearing, Discussion/Action: Variance 23-04 and Conditional Use Permit 23-07 for Mark Gaddis to allow the deviation of the Residential Zone Property Development Standards for maximum height and side yard setback requirements for an accessory structure located at 121 North F Street (APN 064-042-0001). The project is categorically exempt from the California Environmental Quality Act (CEQA) under Section 15301, Existing Facilities.

The public hearing was opened at 7:15 p.m.

The staff report was presented by Yvonne Cordero City Planner.

Continued Public Hearing to April 24, 2024.

Moved by Abatti, seconded by Rivera to continue the public hearing to the next regular scheduled Planning Commission meeting of April 24th to give Mr. Gaddis time to collect more information.

AYES: Abatti, Terrazas-Baxter, Rivera and Harvey

NOES: None

ABSTAIN: Winkler

ABSENT: None

MOTION CARRIES: 4-0

E. REPORTS:

E-1: Commissioners reported on their activities and concerns since last planning commission meeting.

E-2 Staff Reports: None

Seeing no further business before the Commission, Chairperson Harvey adjourned the meeting at 7:44 p.m.

IN WITNESS WHEREOF, I have hereunto set my hand and affixed the official seal of the City of Imperial, California this _____ day of June, 2024.

KRISTINA SHIELDS
City Clerk



PLANNING AND TRAFFIC COMMISSION
Veronica Harvey – Chairperson
Ruben Rivera – Vice Chairperson
Alice Abatti – Commissioner
Rebecca Terrazas-Baxter – Commissioner
Lisa Winkler-Commissioner

MINUTES

PLANNING COMMISSION
TRAFFIC COMMISSION

220 West 9th Street
IMPERIAL, CA 92251

WEDNESDAY, JUNE 12, 2024
6:30 P.M.

- A. **PLANNING COMMISSION CALL TO ORDER:**
Chairperson Harvey called the meeting to order at 6:38 p.m.

ROLL CALL:

Commissioners Present: Chairperson Harvey, Vice-Chairperson Rivera, Commissioner Terrazas-Baxter

Absent: Commissioner Abatti, Commissioner Winkler

City Staff Present:

Dennis Morita, City Manager
Katherine Turner, City Attorney
Othon Mora, Community Development Director
Yvonne Cordero, Planner
Fernando Williams, Engineering Technician

PLEDGE OF ALLEGIANCE: Led by Chairperson Harvey

ADJUSTMENTS TO THE AGENDA: None

- B. **PUBLIC APPEARANCES**

B-1. Matters not appearing on the agenda. None

- C. **PUBLIC HEARING: (DISCUSSION/ACTION-RECOMMEND/DENY):**

C-1: Subject: Continued Public Hearing, Discussion/Action: Variance 23-04 and Conditional Use Permit 23-07 for Mark Gaddis to allow the deviation of the Residential Zone Property Development Standards for maximum height and side yard setback requirements for an accessory structure located at 121 North F Street (APN 064-042-0001). The project is categorically exempt from the California Environmental Quality Act (CEQA) under Section 15301-Existing Facilities.

Chairperson Harvey continued the public hearing at 6:50 p.m. Yvonne Cordero, Planner, provided an update on the project and explained that the Imperial Irrigation District (IID) is providing Mr. Gaddis with a cost sheet to reroute the power pole and power lines that are in violation of IID's regulations. City Attorney Katie Turner elaborated that she and IID's Legal Counsel, Geoff Holbrook, confirmed IID staff has been working on the project and is scheduled to meet to resolve this matter. Mr. Morita stated that in conversation with IID staff, IID would consider allowing the structure if Mr. Gaddis bore the cost of the pole relocation and addressed with the right-of-way issue. Ms. Turner, in agreement with Mr. Morita, recommended continuing the public hearing to the next scheduled

meeting to provide a final action. Ms. Turner further requested IID staff and the applicant be present at the continued public hearing to answer any questions.

Commissioner Terrazas-Baxter motioned to continue the public hearing to June 26, 2023. Vice-Chairperson Rivera seconded the motion. The motion passed unanimously with a 3-0 vote.

C-2 Subject: Public Hearing, Discussion/Action: Implementation of a Vehicle Miles Traveled methodology for evaluating transportation impacts under the revised California Environmental Quality Act guidelines as per Senate Bill 743. The project is categorically exempt from the California Environmental Quality Act under Section 15268-Ministerial Projects.

Chairperson Harvey opened the project's public hearing at 6:47 p.m. Fred Minagar from Minagar and Associates, Inc. presented the 2023 Implementation of a Vehicle Miles Traveled and CEQA Threshold Study to the Planning Commission and addressed their questions.

Chairperson Harvey closed the public hearing at 8:08 p.m. and Commissioner Terrazas-Baxter made the motion to approve Resolution PC2024-05 recommending City Council approval of the 2023 Implementation of a Vehicle Miles Traveled and CEQA Threshold Study. Vice-Chairperson Rivera seconded the motion. The motion passed unanimously with a 3-0 vote.

Chairperson Harvey adjourned the Planning Commission meeting at 8:09 p.m.

D. TRAFFIC COMMISSION NEW BUSINESS: (DISCUSSION/ACTION-RECOMMEND/DENY):

D-1: Discussion/Action: Removal of Pedestrian Crosswalk Located at 400 South Imperial Avenue, between West 4th Street and West 5th Street. This project is categorically exempt from the California Environmental Quality Act under Section 15301 (Class 1) -Existing Facilities.

Chairperson Harvey opened the Traffic Commission meeting at 8:09 p.m.

Fernando Williams, Engineering Technician presented the crosswalk removal project to the Traffic Commission and answered the Commissioners' questions.

Commissioner Terrazas-Baxter motioned to recommend the removal of the pedestrian Crosswalk located at 400 South Imperial Avenue. Vice-Chairperson Rivera seconded the motion. The motion passed unanimously with a 3-0 vote.

E. REPORTS:

E-1: Commissioners' Reports: None

E-2 Staff Reports: Othon Mora, Community Development Director, announced the Neckel Road closure is extended from June 20, 2024 to June 30, 2024.

F. ADJOURNMENT

F-1. Subject: Adjourn the Planning and Traffic Commission meeting until the next regularly scheduled meeting on June 26, 2024, at 6:30pm.

Chairperson Harvey adjourned the Planning and Traffic Commission meeting at 8:20 p.m.



Staff Report

Agenda Item No. E-1

To: City of Imperial Planning Commission
From: Yvonne Cordero, Planner
Date: June 21, 2024
Item: Variance 23-04 and Conditional Use Permit 23-07 – Deviation from the Residential Property Development Standards

Applicant:	Mark Gaddis
Project Location:	121 N. F Street
Zoning:	R-1 Single-Family Residential
Environmental:	Categorically Exempt from CEQA – 15301 Existing Facilities
Recommendation:	Staff does not recommend Planning Commission approval of Variance 23-04 and Conditional Use Permit 23-07.

Background

Mark Gaddis submitted a Planning Application for the legalization of an existing metal and fabric accessory structure constructed at his residence located at 121 N. F Street. The accessory structure has an overall height of thirteen feet and six inches and was constructed with ten-inch setbacks from the property line. The City of Imperial's

Residential Property Development Standards for Accessory Structures require a setback measurement of three feet and a maximum height of twelve feet for accessory structures.

Mr. Gaddis was paid a courtesy call by our Code Enforcement Division to obtain a building permit for the legalization of his accessory structure. He informed Code Enforcement that the structure had been constructed approximately one year prior to the City's notice. During the building permit review process, staff advised Mr. Gaddis of the structure's height and setback violations and he opted to apply for a variance to deviate from the required setback and height requirements.

The City of Imperial's Development Review Committee reviewed Variance 23-04 and Conditional Use Permit 23-07 and recommend the accessory structure be either removed or modified to comply with the City's Residential Property Development Standards. Upon review of the project, the Development Review Committee requested the Imperial Irrigation District's review of the structure, due to the proximity of IID's power poles and power lines located at the Northwest corner of Mr. Gaddis' property shown in the picture below. IID conducted a site inspection and verified the structure was constructed within IID's Right of Way/Easement and provided their Distribution Line Clearance Specifications detailing the area distances that are to be clear of buildings/structures for 15KV power poles/lines (Attachment B) and Regulation No. 23-Clearance Requirements for Power Line Corridors (Attachment C).



Community Development staff met Mr. Gaddis at his property on February 9, 2024 to verify the structure's measurements. Staff's measurements confirmed that the accessory structure is in violation of IID's Distribution Line Clearances and the City's Property Development Standards. Mr. Gaddis informed staff he submitted an IID Encroachment Permit for permission to encroach within the IID's right of way/easement, but the IID Encroachment Permit was rejected (Attachment D). IID's recommendation is for Mr.

Gaddis to reapply for an Encroachment Permit after modifying the accessory structure to conform with IID's Regulation No. 23 (Attachment C).

The City of Imperial Planning Commission conducted a public hearing on March 27, 2024. The Planning Commission directed Mr. Gaddis to inquire about what other recourse or appeals process was available to him after IID's Encroachment Permit denial. The public hearing was unanimously continued by the Planning Commission pending the information to be provided by Mr. Gaddis at the continued public hearing scheduled for April 24, 2024.

Mr. Gaddis contacted IID's Real Estate Section and IID requested a letter from City staff summarizing the Planning Commission's instructions and he provided staff with the Encroachment Permit rejection email (Attachment D).

At the April 24, 2024, continued public hearing the Planning Commission unanimously voted on giving Mr. Gaddis an additional six weeks to contact IID and obtain a resolution. The public hearing was once again continued to June 12, 2024. Mr. Gaddis provided a project update statement (Attachment F), indicating IID is formulating a cost sheet to reroute power lines and the power pole located on his property. Staff contacted IID regarding Mr. Gaddis' project for an update, but did not receive any information by the June 12, 2024 public hearing and continued the public hearing to June 26, 2024. Direction was given for staff to contact IID for a project update and to request an IID representative be present at the June 26 continued public hearing.

Staff received a project update from IID and provided a power pole removal and power line rerouting plan (Attachment G). This plan confirms that the removal of the overhead power lines from power pole #1 (6372) to pole #3 (6373) and the recordation of the IID-approved right-of-way/easement will resolve the infractions. Mr. Gaddis' cost to execute the removal and rerouting plan is \$83,820.56, as demonstrated in IID's cost estimate (Attachment H). Mr. Gaddis indicated he intends to move forward with IID's proposition to remove the power poles and reroute the power lines to clear IID's infractions and to allow him to preserve his shade structure (Attachment I).

Eliminating IID's infractions will allow the City's Planning Commissioners to move forward and address the variance to allow the shade structure's setbacks that deviate from the three-foot setback required in our Residential Zone's Property Development Standards. It will also allow the proper evaluation of the Conditional Use Permit request to permit the existing structure's height of thirteen feet, 6 inches to exceed the Residential Zone's twelve-foot height limitations for accessory structures.

Project Location



Aerial View



Required Findings for Variance 23-03:

In order to approve Variance 23-03, the Planning Commission is required to review six findings per Section 24.19.400 of the City of Imperial's Zoning Ordinance. The findings are listed below, along with the reasons why staff considers that the findings are or are not met in this case. These findings are:

- 1. There are special circumstances, such as size topography, location or surroundings applicable to the property or the intended use of the property, and because of this, the strict application of the Zoning Ordinance deprives the property of privileges enjoyed by other properties in the vicinity under identical zoning classification.**

There are no special circumstances that apply to this property regarding its size, shape or topography that deprive the property of the privileges enjoyed by other properties within the Residential Zone. The subject parcel's size is approximately 9,074 square feet, much larger than the minimum lot size of 6,500 square feet in a Residential Zone, therefore allowing sufficient space for the required three-foot setbacks.

- 2. The granting of the variance or its modification is necessary for the preservation and enjoyment of a substantial property right possessed by other property in the same vicinity and zone and denied to the property for which the variance is sought.**

Although Mr. Gaddis' property right to construct an accessory structure is recognized and has not been denied, the granting of the variance, in its original or modified form, is not necessary to preserve the property owner's right possessed by other residential properties in the vicinity. Permitted accessory structures in Residential Zones comply with the Residential Zone's Property Development Standards by going through the City of Imperial's Community Development's building permit review process or by the approval of a variance.

- 3. That granting the variance or its modification will not be materially detrimental to the public health, safety or welfare, or injurious to the property or improvements in such vicinity and zone in which the property is located.**

Granting the variance is a potential detriment to the public health, safety and welfare to the property and properties in the project site's vicinity. The applicant built the structure without going through the proper building permit process that includes foundation, structural, certified engineered, property development standards plan review, and all subsequent building inspections to verify the structure's integrity.

- 4. The variance will not constitute a privilege inconsistent with the limitations upon other properties in the vicinity and zone in which such property is situated.**

The approval of this variance will be granting a special privilege within the neighborhood and zone as other residential accessory structures that are reviewed by the City of Imperial's Community Development Department prior to being constructed are only approved when the building plans and inspections comply with the Property Development Standards set forth in Section 24.03.120 of the Residential Zone Ordinance.

- 5. The granting of this variance does not allow a use or activity which is not otherwise expressly authorized by the zoning regulation governing the parcel of property.**

Granting the approval of Variance 23-04 will allow a use unauthorized by the Residential Zone governing the parcel located at 121 N. F Street by deviating from the Residential Property Development Standards set forth in Section 24.03.120.

- 6. That granting the variance or its modification will not be incompatible with the City of Imperial General Plan.**

Variance 23-04 will be incompatible with The City of Imperial's General Plan's Safety Element. Objective 8 states the City is responsible for protecting the public to the maximum extent possible. Additionally, the Hazard Management Element's goals and objectives are to contain mitigation measures to protect the public health, safety and welfare. The applicant built the structure without going through the proper building permit process that includes foundation, structural, certified engineered, property development standards plan review, and all subsequent building inspections to verify the structure's integrity.

Required Findings for Conditional Use Permit 23-07:

The Zoning Ordinance provides flexibility in the regulation of uses to ensure that unusual characteristics of certain uses are properly addressed in furtherance of the Imperial Zoning Ordinance. Section 24.19.340 of the City of Imperial Zoning Ordinance requires that the Commission make specific findings be made when reviewing a Conditional Use Permit. The required findings are listed below in ***bold italics***, followed by an evaluation:

- 1. That the proposed location, size, design, and operating characteristics of the proposed use is in accord with the Title and Purpose of this Ordinance, the purpose of the zone in which the site is located, the Imperial General Plan, and the development policies and standard of the City.***

The subject site is located within the Residential Single-Family Zone, which is intended as an area for single-family residential development. Additional uses, such as the accessory structure, that are complementary to and that

exist in harmony with a single-family residential neighborhood are permitted, provided that they follow the Residential Property Development Standards. Exceeding the height limitations requires a Conditional Use Permit.

- 2. That the location, size, design, and operating characteristics of the proposed use will be compatible with and will not adversely affect or be materially detrimental to adjacent uses, residents, buildings, structures, or natural resources with consideration given to those items listed in Section 24.19.340.B of the Imperial Zoning Ordinance.***

The accessory structure, a metal and fabric shade structure utilized for the storage of a recreational vehicle, does not propose to be a detriment that will adversely affect his residence, or the adjacent residential uses, provided he legalizes the structure by going through the building permit process and complying with all building codes to verify the accessory structure's integrity.

- 3. That the proposed location, size, design, and operating characteristics of the proposed use and the conditions under which it would be operated or maintained will not be detrimental to the public health, safety, or welfare, or materially injurious to properties or improvements in the vicinity.***

Approval of Conditional Use Permit 23-07 is a potential detriment to the public health, safety and welfare to the property and properties in the project site's vicinity. The applicant built the structure without going through the proper building permit process that includes foundation, structural, certified engineered, property development standards plan review, and all subsequent building inspections to verify the structure's integrity.

- 4. That the proposed Conditional Use will comply with each of the applicable provisions of the Zoning Ordinance, except for any approved Variance.***

The existing accessory structure does not comply with the provisions of the Residential Zoning Ordinance's Property Development Standards by being constructed with ten-inch setbacks and within a utility easement.

Environmental:

This project qualifies for a Categorical Exemption according to the California Environmental Quality Act (CEQA), Section 15301, "Existing Facilities", and is determined to be exempt from further environmental review requirements contained in CEQA.

Staff Recommendation:

Staff recommends the Planning Commission conduct a public hearing to receive comments for and against the project. Unless sufficient evidence to the contrary is presented at the public hearing, staff recommends that the Planning Commission **DENIES APPROVAL** of Variance 23-04 to allow the deviation of the required setbacks defined in the City of Imperial's Property Development Standards and Conditional Use Permit 23-07 to allow the existing accessory structure with a height that exceeds the City of Imperial's Property Development Standards.

Attachments

- Attachment A - DRAFT Resolution PC2024-01 with Conditions of Approval
- Attachment B - IID Distribution Line Clearance Guidelines
- Attachment C - IID Regulation No. 23
- Attachment D - IID Encroachment Permit Application Rejection Notice
- Attachment E - Applicant's Accessory Structure's Building Plans
- Attachment F - Applicant's project status statement
- Attachment G - IID Power Pole Removal and Power Line Rerouting Plan
- Attachment H - IID Cost Estimate
- Attachment I - Applicant's Email Stating Intention to Proceed with IID's Proposed Plan

Respectfully submitted,

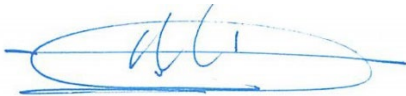

Othon Mora, MCM, CBO
Community Development Director

ATTACHMENT A
DRAFT RESOLUTION NO. PC2024-01

A RESOLUTION OF THE PLANNING COMMISSION, OF THE CITY OF IMPERIAL, DENYING APPROVAL OF VARIANCE 23-04 AND CONDITIONAL USE PERMIT 23-07 FOR MARK GADDIS TO ALLOW THE DEVIATION OF THE RESIDENTIAL ZONE'S PROPERTY DEVELOPMENT STANDARDS FOR MAXIMUM HEIGHT AND SETBACK REQUIREMENTS FOR AN ACCESSORY STRUCTURE LOCATED AT 121 NORTH F STREET (APN 064-042-001)

WHEREAS, Mark Gaddis submitted a variance request for the deviation of the Residential Zone's Property Development standards for an accessory structure exceeding the maximum height limitations and setback requirements; and

WHEREAS, a duly notified public hearing was held by the Planning Commission during a meeting on March 27, 2024, April 24, 2024, June 12, 2024 and June 26, 2024; and

WHEREAS, upon hearing and considering all testimony and arguments, analyzing the information submitted by staff and considering any written comment received, the Planning Commission considered all facts relating to the request for Variance 23-04 Conditional Use Permit 23-07.

NOW, THEREFORE, BE IT RESOLVED by the Planning Commission of the City of Imperial grants as follows:

- A) That the foregoing recitations are true and correct; and
- B) The project has been reviewed in accordance with the requirements set forth by the City of Imperial for implementation of the California Environmental Quality Act; and
- C) Installation and alteration of the property and deviation from the Residential Zone's Property Development Standards are ministerial and therefore categorically exempt from the California Environmental Quality Act per Section 15301.
- D) That based on the evidence presented at the public hearing, the Planning Commission hereby determines that the project is Categorical Exempt under Section 15301 of the California Environmental Quality Act; and
- E) That based on the evidence presented at the public hearing, the Planning Commission hereby **DENIES APPROVAL of Variance 23-04 and Conditional Use Permit 23-07** for Mark Gaddis to allow for the deviation of the Residential Zone's Property Development Standards for maximum height and setback requirements, based on the following findings:

- 1. There are special circumstances, such as size topography, location or surroundings applicable to the property or the intended use of the property, and because of this, the strict application of the Zoning Ordinance deprives the property of privileges enjoyed by other properties in the vicinity under identical zoning classification.**

There are no special circumstances that apply to this property regarding its size, shape or topography that deprive the property of the privileges enjoyed by other properties within the Residential Zone. The subject parcel's size is approximately 9,074 square feet, much larger than the minimum lot size of 6,500 square feet in a Residential Zone, therefore allowing sufficient space for the required three-foot setback.

- 2. The granting of the variance or its modification is necessary for the preservation and enjoyment of a substantial property right possessed by other property in the same vicinity and zone and denied to the property for which the variance is sought.**

Although Mr. Gaddis' property right to construct an accessory structure is recognized and has not been denied, the granting of the variance, in its original or modified form, is not necessary to preserve the property owner's right possessed by other residential properties in the vicinity. Permitted accessory structures in Residential Zones comply with the Residential Zone's Property Development Standards by going through the City of Imperial's Community Development's building permit review process or by the approval of a variance.

- 3. That granting the variance or its modification will not be materially detrimental to the public health, safety or welfare, or injurious to the property or improvements in such vicinity and zone in which the property is located.**

Granting the variance is a potential detriment to the public health, safety and welfare to the property and properties in the project site's vicinity. The applicant built the structure without going through the proper building permit process that includes foundation, structural, certified engineered, property development standards plan review, and all subsequent building inspections to verify the structure's integrity.

- 4. The variance will not constitute a privilege inconsistent with the limitations upon other properties in the vicinity and zone in which such property is situated.**

The approval of this variance will be granting a special privilege within the neighborhood and zone as other residential accessory structures that are reviewed by the City of Imperial's Community Development Department prior to being constructed are only approved when the building plans and

inspections comply with the Property Development Standards set forth in Section 24.03.120 of the Residential Zone Ordinance.

- 5. The granting of this variance does not allow a use or activity which is not otherwise expressly authorized by the zoning regulation governing the parcel of property.**

Granting the approval of Variance 23-04 will allow a use unauthorized by the Residential Zone governing the parcel located at 121 N. F Street by deviating from the Residential Property Development Standards set forth in Section 24.03.120.

- 6. That granting the variance or its modification will not be incompatible with the City of Imperial General Plan.**

Variance 23-04 will be incompatible with The City of Imperial's General Plan's Safety Element. Objective 8 states the City is responsible for protecting the public to the maximum extent possible. Additionally, the Hazard Management Element's goals and objectives are to contain mitigation measures to protect the public health, safety and welfare. The applicant built the structure without going through the proper building permit process that includes foundation, structural, certified engineered, property development standards plan review, and all subsequent building inspections to verify the structure's integrity.

- F) The City Attorney is authorized to make minor typographical changes to this Resolution that does not change the substance of this Resolution.

PASSED, ADOPTED AND APPROVED by the Planning Commission of the City of Imperial, this 26th day of June, 2024.

Planning Commission Chairperson

ATTEST:

City Clerk

CONDITIONS OF APPROVAL

VARIANCE 23-04

Mark Gaddis

121 N. F Street

APN 064-042-001

1. Applicant understands that the Planning Commission's decision may include:
 - a) approval of Resolution PC2024-01 to maintain the existing carport structure located at the western property line of APN 064-042-001, approving the deviation from the City of Imperial's Property Development Standards setback and height requirements; or
 - b) approval of Resolution PC2024-01 with additional conditions imposed during the public hearing by the City of Imperial's Planning Commission; or
 - c) denial of Resolution PC2024-01 effecting the removal or reconstruction of the existing side yard carport structure to comply with the City of Imperial's Residential Development Standards for accessory structures and the Imperial Irrigation District's Right of Way Building Clearance Regulations.
2. Applicant must obtain a building permit from the City of Imperial's Community Development Department along with any required development and/or construction plans, including payment of any related project fees.
3. Applicant shall not hold the City of Imperial or any of its employees responsible for any incidents regarding Variance 23-04.
4. The provisions of Variance 23-04 are to run with the land/project and shall bind the current and future owner(s) successor(s) in interest, assignee(s) and/or transferor(s) of said project.
5. The Applicant shall be responsible for the removal of all graffiti from the property within seventy-two (72) hours of its appearance on the property.
6. The Applicant shall be responsible for maintaining the property free of litter at all times.
7. Applicant shall comply with all local, State and Federal laws, regulations, rules, ordinances, and standards as they pertain to this project, whether specified herein or not. Where conflicts occur, the most stringent shall apply.
8. The approval of Variance 23-04 shall not constitute the waiver of any requirement of the City's Ordinances or regulations, except where a condition set forth herein specifically provides for a waiver.
9. The Applicant shall pay all applicable fees as required by the city.

10. Applicant must obtain an approved building permit from the Community Development Department within six (6) months of approval of Variance 23-04. If the applicant does not obtain an approved building permit from the Community Development Department, Variance 23-04 becomes null and void based on the final date of approval.
11. If the Community Development Department finds and determines that the Applicant or successor-in-interest has not complied or cannot comply with the terms and conditions of Variance 23-04, or the Planning/Building Division determines that the permitted activities constitute a nuisance, the City shall provide the Applicant with notice and opportunity to comply with the enforcement or abatement order. If after receipt of the order (1) Applicant fails to comply, and/or (2) Applicant cannot comply with the conditions set forth in the Variance, then the matter shall be referred to the Planning Commission, or to the appropriate enforcement authority, for modification, suspension, or termination.
12. As between the City and the Applicant, any violation of Variance 23-04 approval may be a "nuisance per se". The City may enforce the terms and conditions of Variance 23-04 in accordance with its Codified Ordinances and/or State law. The provisions of this paragraph shall not apply to any claim of nuisance per se brought by a third party.
13. Applicant shall not be permitted to maintain a "nuisance", which is anything which: (1) is injurious to health, or is indecent or offensive to the senses, or an obstruction to the free use of property, so as to interfere with the comfortable enjoyment of life or property, and/or (2) affects at the same time an entire community or neighborhood, or any considerable number of persons, although the extent of the annoyance or damage inflicted upon individuals may be unequal, and/or (3) occurs during or as a result of the approved project.

ATTACHMENT B

6.20

AREA TO BE CLEAR OF BUILDINGS

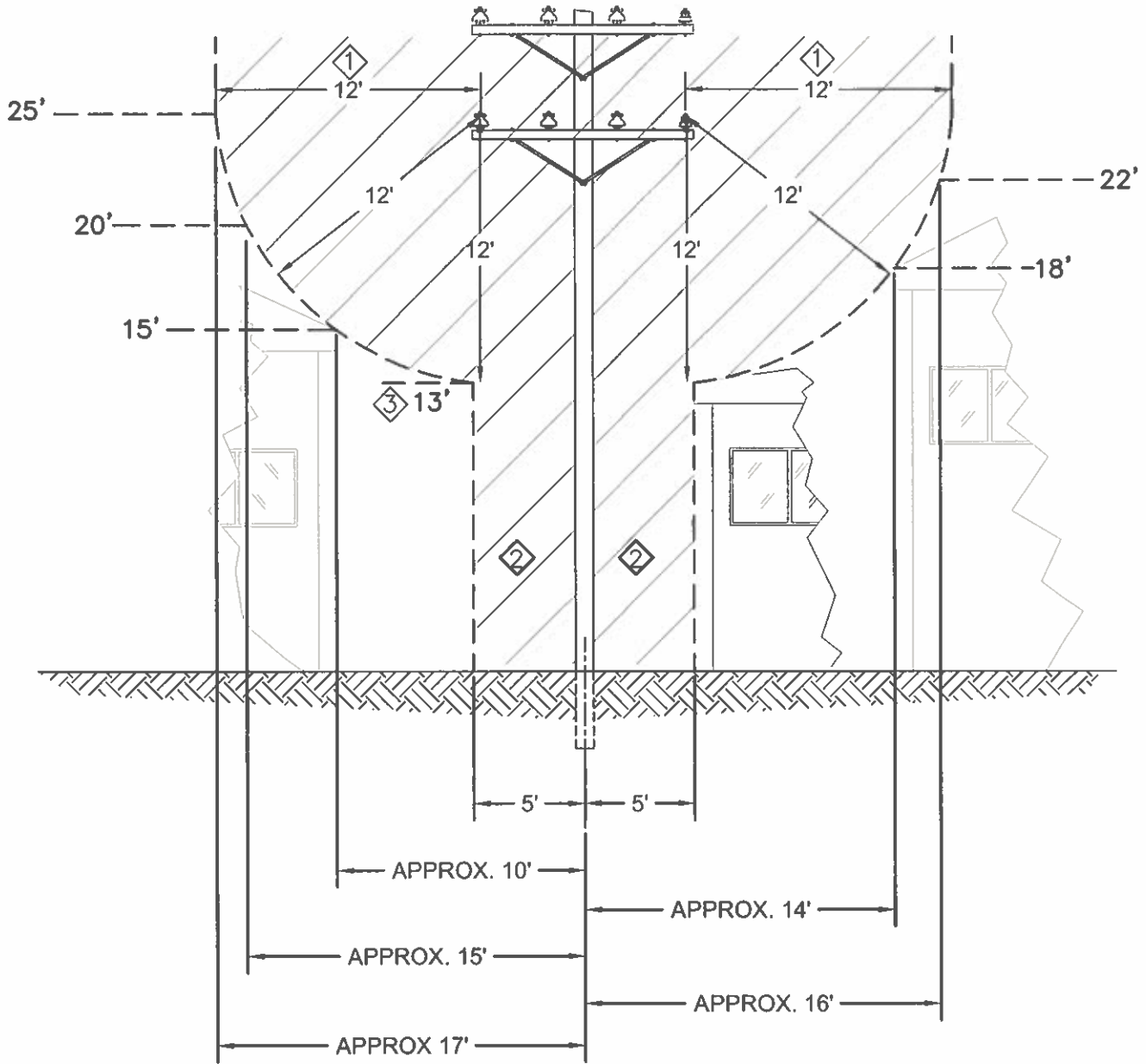

NOTES:

- ① BUILDING STRUCTURES TO CONDUCTOR, CLEARANCE TO BE 12 FT. MIN RADIAL FOR 15KV CIRCUITS.
- ② CLEARANCE TO BE 5 FT. RADIAL FROM CENTERLINE OF POWER POLE, IID RIGHT OF WAY.
NO STRUCTURES ALLOWED IN IID RIGHT OF WAY.
- ③ BUILDING STRUCTURE TO BE A MAXIMUM HEIGHT OF 13 FT. IF DIRECTLY OUTSIDE OF IID RIGHT OF WAY.
- 4. CLEARANCES SHOWN ARE FOR DOUBLE CIRCUITS ONLY, FOR SINGLE CIRCUIT CLEARANCES NOTE ① APPLIES.

IMPERIAL IRRIGATION DISTRICT

DRAWN BY	<i>JR</i>
REVIEWED	<i>MS</i>
APPROVED	<i>MS</i>
REVISION	REV 01
DATE	2-11-2013



**EXISTING AND NEW LINE CONDITIONS
15KV DISTRIBUTION
BUILDING CLEARANCES**

ATTACHMENT C

REGULATION NO. 23

CLEARANCE REQUIREMENTS FOR POWER LINE CORRIDORS

A. GENERAL PROHIBITION

No person shall cause interference with or pose a threat to the reliability of the District's transmission or distribution lines or create a safety hazard to the public by encroaching upon the District's rights-of-way in violation of the standards set forth herein.

B. PROHIBITED ACTIONS IN DISTRICT RIGHTS-OF-WAY

Within District power line rights-of-way, persons may not:

- (1) Build or expand a structure.
- (2) Modify power line ground clearance by adding material, storing material, equipment, crops, haystacks or other means, resulting in ground clearance non-conformance to California Public Utilities Commission General Order 95 requirements as set forth in Exhibit A.
(Reference CPUC, General Order No. 95, Rule 37, Minimum Clearances of Wires above Railroads, Thoroughfares, Buildings, Case No. 4).
- (3) Dig, or otherwise undermine power line structures.
- (4) Modify drainage or protection berms.
- (5) Store or stack wood, earth, waste, debris, materials, crops, machinery, equipment, supplies, haystacks, or similar personalty.
- (6) Plant trees, palms or other vegetation with the ability to grow closer than the minimum clearances set forth in Exhibit B.
- (7) Ignite fires, burn debris, materials, crops, haystacks.
(Reference California Public Resources Code Section 4293, Mountainous, Forest-Brush- and Grass-Covered Lands).

C. PERSONNEL SAFETY CLEARANCES

- (1) No person, firm, corporation, or agent of same, shall require or permit an employee to perform any function in proximity to energized high-voltage lines, to enter upon any land, building, or other premises, and there engage in any excavation, repair, or other operation; or to erect, install, operate, or store, in or upon premises, any tools, machinery, equipment, materials, or structures unless or until danger from accidental contact with said high-voltage lines has been effectively guarded against.
- (2) Persons other than qualified line-clearance tree trimmers and trainees shall not approach energized high-voltage power lines closer than as set forth in Exhibit C.
(Reference California Code of Regulations, Title 8, Section 2950, Table 1 Operations).

ATTACHMENT C

- (3) The execution, operation or dismantling of any boom-type lifting or hoisting equipment, or any part thereof, closer than the minimum clearances set forth in Exhibit D, below, shall be prohibited.

(Reference California Title 8, Section 2946, Provisions for Preventing Accidents Due to Proximity to Overhead Lines).

- (4) The storage of tools, machinery, equipment, supplies, materials, or apparatus, under, over, or adjacent to energized overhead high-voltage lines, is hereby expressly prohibited, if at any time during the handling or other manipulation it is possible to bring such tools, machinery, equipment, supplies, materials, or apparatus, or any part thereof, closer than the minimum clearances from such lines as set forth in Exhibit D, below.

(Reference California Title 8, Section 2946, Provisions for Preventing Accidents Due to Proximity to Overhead Lines).

D. HAZARDS

Hazards that may fall onto overhead high-voltage lines shall be removed.

(Reference CPUC, General Order No. 95, Section III Requirements for All Lines, Rule 35, Vegetation Management).

E. ENFORCEMENT

The District is hereby authorized to enforce the provisions hereof by all legal and equitable remedies including the discontinuance or refusal of electrical service to the subject property and when deemed necessary and appropriate in order to protect the health and safety of the community or reliability of the energy system, remove the encroachment or obstruction; the cost of such removal to be charged to the property owner. The District shall provide notice to the property owner of intended enforcement actions except where there is an imminent threat to the health or safety of the community or to the reliability of the District's energy systems.

ATTACHMENT C

Exhibit A

California Public Utilities Commission, Rules for Overhead Electric Line Construction, General Order No. 95, Section III, Requirements for All Lines, Rule 37 Minimum Clearances of Wires above Railroads, Thoroughfares, Buildings, Etc., Case No. 4 (*excerpt, see Order for additional details*)

Case No.	Nature of Clearance	Span Wires (Other than Trolley Span Wires) Overhead Guys and Messengers	Communication Conductors (Including Open Wire, Cables and Service Drops), Supply Service Drops of 0 - 750 Volts	Supply Conductors of 0 - 750 Volts and Supply Cables Treated as in Rule 57.8	Supply Conductors and Supply Cables, 750 - 22,500 Volts	Supply Conductors and Supply Cables, 22,500 - 300,000 Volts
4	Above Ground along thoroughfares in rural districts or across other areas capable of being traversed by vehicles or agricultural equipment	15 Feet	15 Feet	19 Feet	25 Feet	30 Feet

Exhibit B

California Public Resources Code, Division 4, Part 2, Chapter 3 Mountainous, Forest-, Brush- and Grass-Covered Lands, Section 4293 (*excerpt, see Code for additional details*)

Clearance in All Directions Between All Vegetation and All Energized Conductors Which Are Carrying Electric Current	
Operating Voltage	Clearance Distance
2,400 or more Volts, but less than 72,000 Volts	4 FT
72,000 or more Volts, but less than 110,000 Volts	6 FT
110,000 or more Volts	10 FT

ATTACHMENT C

Exhibit C

California Title 8, Group 2, Article 38, Section 2950, Table 1 (*excerpt, see Code for additional details*)

Minimum Approach Distances to Energized Conductors for Persons Other Than Qualified Line Clearance Tree Trimmers and Trainees.	
Nominal Voltage (phase to phase)	Clearance Distance
0 to 1,000	10 FT 0 in.
1,100 to 15,000	10 FT 0 in.
15,100 to 36,000	10 FT 0 in.
72,600 to 121,000	12 FT 4 in.
161,000 to 169,000	14 FT 0 in.
230,000 to 242,000	16 FT 5 in.

Exhibit D

California Title 8, Subchapter 5, Group 2, Article 37, Section 2946, Provisions for Preventing Accidents Due to Proximity to Overhead Lines (*excerpt, see Code for additional details*)

Material Storage and Boom-Type Lifting or Hoisting Equipment Required Clearances Required From Energized Overhead High-Voltage Lines	
Nominal Voltage (phase to phase)	Clearance Distance
600 to 50,000	10 FT
Over 75,000 to 125,000	13 FT
Over 125,000 to 175,000	15 FT
Over 175,000 to 250,000	17 FT

ATTACHMENT D

From: [Nancy Murrieta](#)
To: [Yvonne Cordero](#)
Subject: Fw: 121 North F St. Imperial
Date: Tuesday, April 16, 2024 4:04:08 PM
Attachments: [VPRealEstateMX6071-S_20240227_105111.pdf](#)

CAUTION: This email originated from outside the City of Imperial. Do not click links or open attachments unless you recognize the sender and know the content is safe.

This is the denial I received from the IID, it is the only thing in writing that I have on my end. Please let me know if this is sufficient.

Nancy Murrieta
Office Manager
G/4 Construction
121 North F Street
Imperial, CA 92251
760-355-4332 Office
760-457-5310 Cell

Begin forwarded message:

On Tuesday, February 27, 2024, 9:59 AM, Casillas, Patty <pmcasillas@IID.com> wrote:

Good morning Nancy:

The Imperial Irrigation District received your encroachment application dated January 25, 2024, for the installation of a carport structure located at 121 North F Street in the city of Imperial. Upon review and performing a site inspection, staff has determined that the carport structure has already been installed. Unfortunately, IID cannot approve the encroachment application and plans submitted based on IID Regulation No. 23, which states, in part:

“B. PROHIBITED ACTIONS IN DISTRICT RIGHTS-OF-WAY.

Within District power line rights-of-way, persons may not:

- (1) Build or expand a structure.
- (2) Modify power line ground clearance by adding material, storing material, equipment, crops, haystacks or other means, resulting in ground clearance non-conformance to California Public Utilities Commission General Order 95 requires as set forth in Exhibit A.” (A copy of said regulation is attached for your information.)

Based on this, your encroachment application is rejected. However, should you wish to modify your plans for the carport structure to conform with IID’s Regulation No. 23, you are welcome to resubmit the plans to this office for further review. Please feel free to contact us if you need further information.

Patty Casillas
Real Estate Section
Imperial Irrigation District
P. O. Box 937
Imperial, California 92251
Phone (760) 339-9381 Cell: (760) 791-4640



From: Nancy Murrieta <g4.construction@yahoo.com>
Sent: Tuesday, February 20, 2024 1:44 PM
To: Casillas, Patty <pmcasillas@IID.com>
Subject: Re: 121 North F St. Imperial

[CAUTION] This email originated from **outside** of the **IID**. Do not reply, click on any links or open any attachments unless you trust the sender and know the content is safe.

Good afternoon,
Is there an update on the encroachment permit at 121 N F St in Imperial?
Thank you.

Respectfully,

Nancy Murrieta
Office Manager
G/4 Construction
121 North F Street

MARK GADDIS

121 N. F ST.

FABRIC SHADE LEGALIZATION

APN: 064-042-001

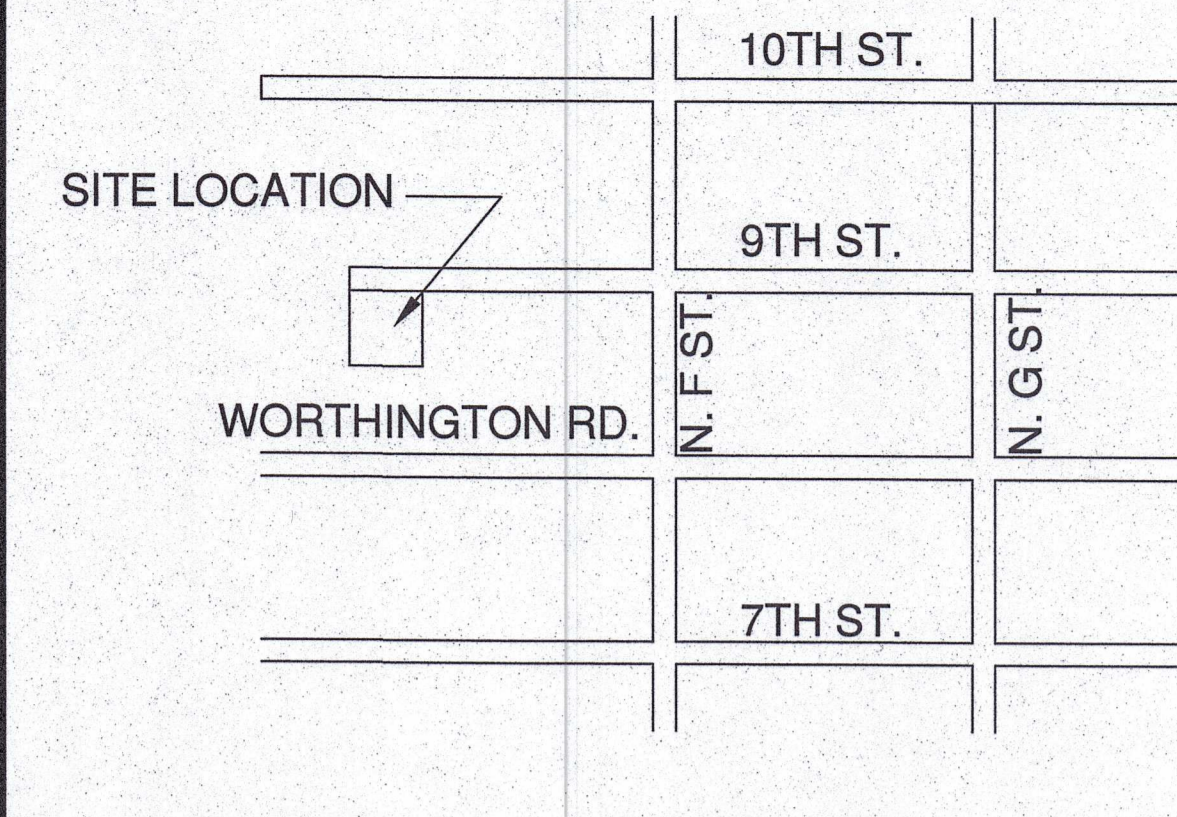

VICINITY MAP

SITE DATA

PROPERTY OWNER: MARK GADDIS
 ADDRESS: 121 N. F ST.
 IMPERIAL, CA 92251
 APN:064-042-001
 LEGAL DESCRIPTION:
 LOT 7 & N 20 FT OF LOT 8 BLOCK 77

DRAWING INDEX

CS _____ SITE PLAN
 S.1 _____ FABRIC SHADE

BUILDING DATA

OCCUPANCY CLASSIFICATION: R
 DESCRIPTION OF USE: RESIDENTIAL
 TYPE OF CONSTRUCTION: TYPE V-B
 SPRINKLERS: NO
 STORIES: 1
 HEIGHT: 9'-0" FT
 LIVING SPACE: +/-2,750 SQ. FT
 GARAGE AREA: +/-840 SQ. FT
 FABRIC SHADE AREA: +/-812 SQ. FT
 HEIGHT: 13'-6" FT

GOVERNING CODES

2022 CALIFORNIA BUILDINGS CODE

SCOPE OF WORK

812 SQ.FT x 13'-6" HIGH FABRIC SHADE TO BE LEGALIZE. FABRIC SHADE CONSTRUCTION WILL ADHERE TO ALL RELEVANT CODES AND REGULATIONS TO ENSURE ITS COMPLIANCE WITH LEGAL REQUIREMENTS.
 DISCLAIMER NOTE:
 ALL PROPERTY LINES ARE APPROXIMATE. IT IS THE OWNER OR CONTRACTOR RESPONSIBILITY TO HIRE A PROFESSIONAL LAND SURVEYOR TO ESTABLISH PROPERTY LINES PRIOR TO ANY CONSTRUCTION.

REQUIRED SPECIAL INSPECTIONS

N/A

DEFERRED SUBMITTAL

N/A

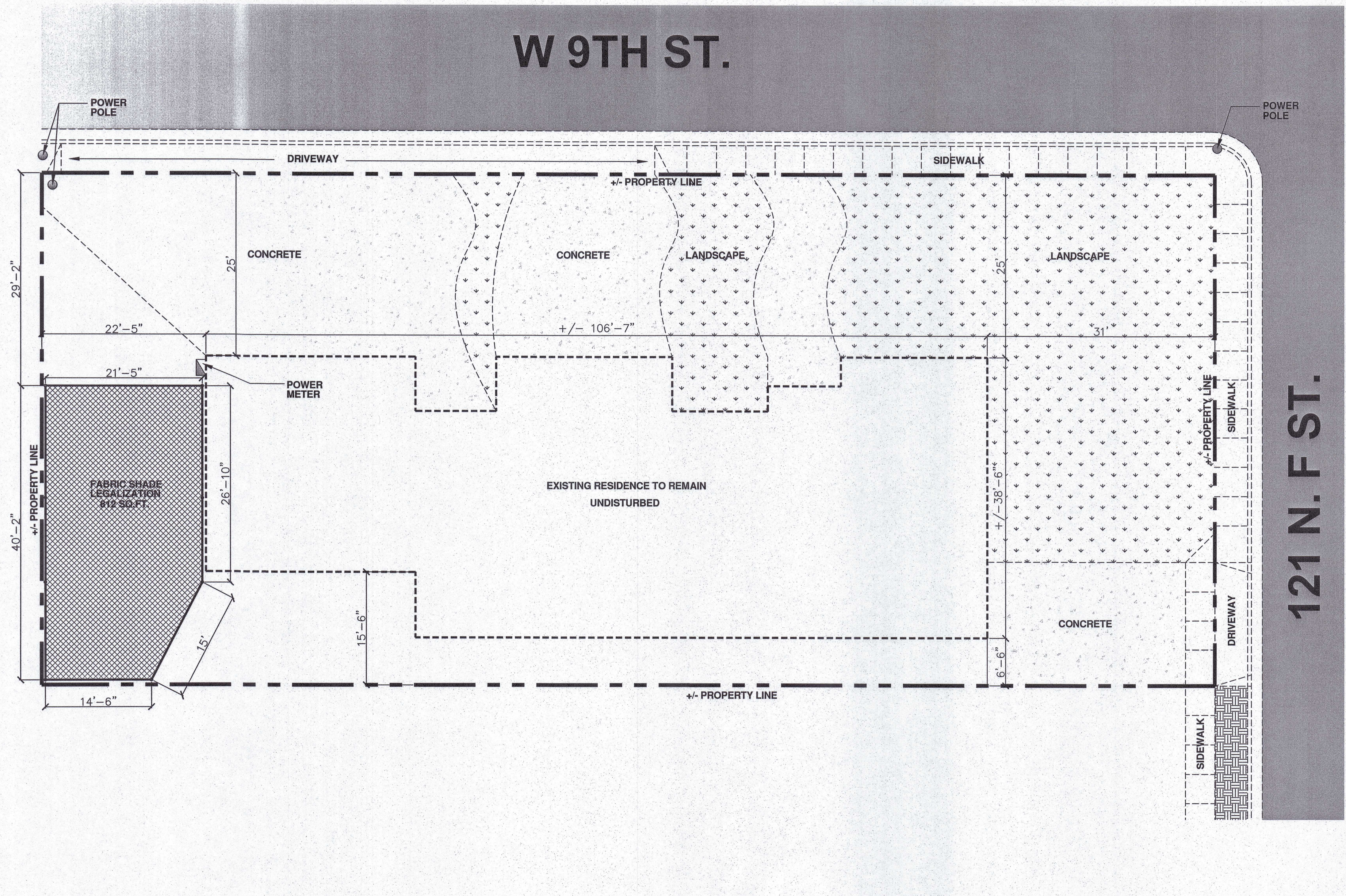

SITE PLAN

SCALE: 1/8" = 1'-0"

- DRAWING STATUS:
- PRELIMINARY DRAWINGS
 - PROGRESS DRAWINGS
 - PLAN CHECK/PERMIT DRAWINGS
 - CONSTRUCTION DOCUMENTS

CALL BEFORE

 UNDERGROUND SERVICE ALERT
 CALL: TOLL FREE
 1-800-422-4133
 YOU DIG
 TWO WORKING DAYS BEFORE YOU DIG

 FERRER Group LLC
 760-601-4667
 info@ferrer.com
 1000 West State Ave., El Centro CA 92243

REVISIONS	No.	DESCRIPTION

BY:	DATE:	PROJECT ADDRESS:
JFT	10/03/2023	121 N. F ST. IMPERIAL, CA 92251
JOB NUMBER: 2023-101	CLIENT: MARK GADDIS	

SHEET
CS

ATTACHMENT E

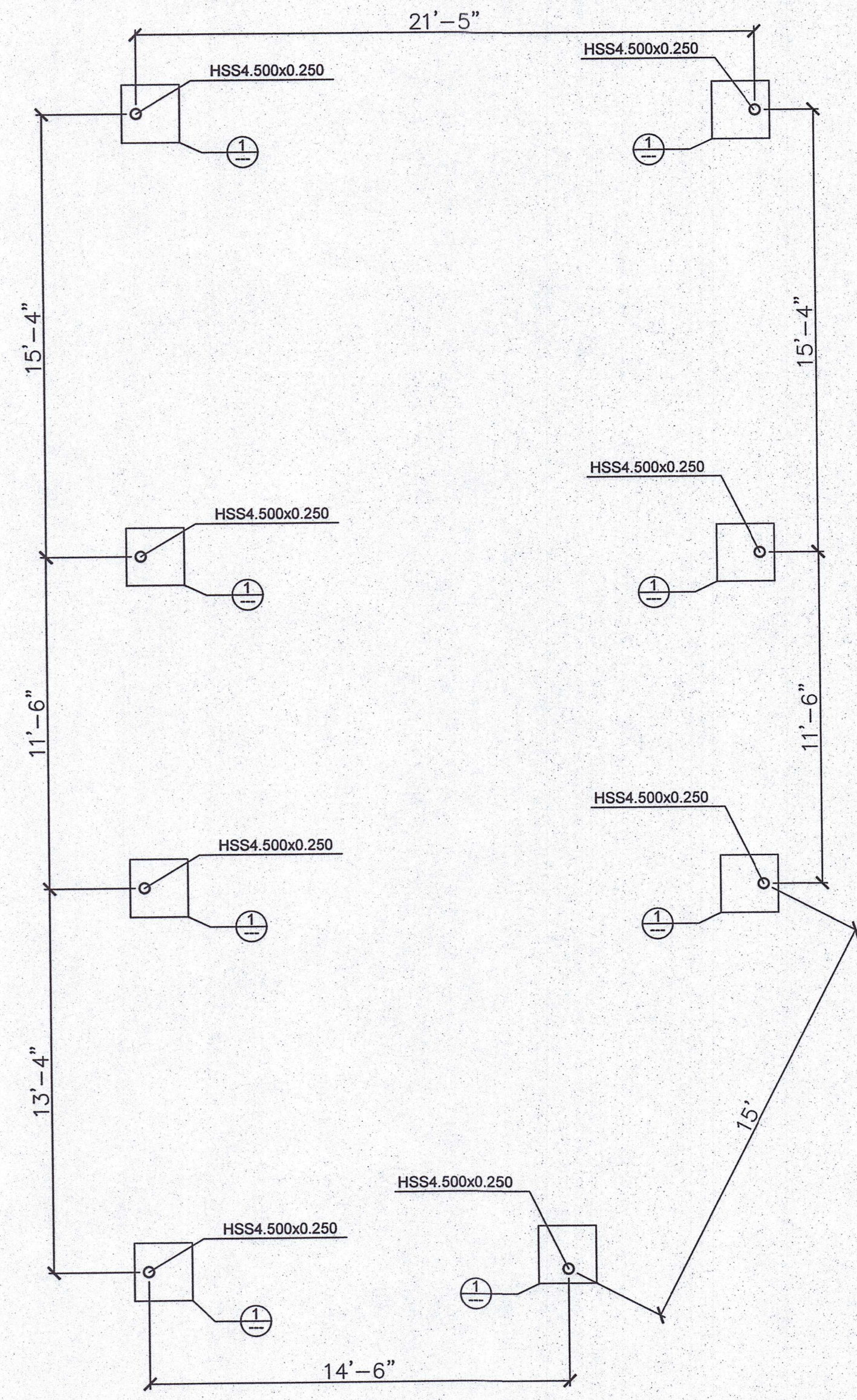

FOUNDATION PLAN

SCALE 1/4" = 1'-0"

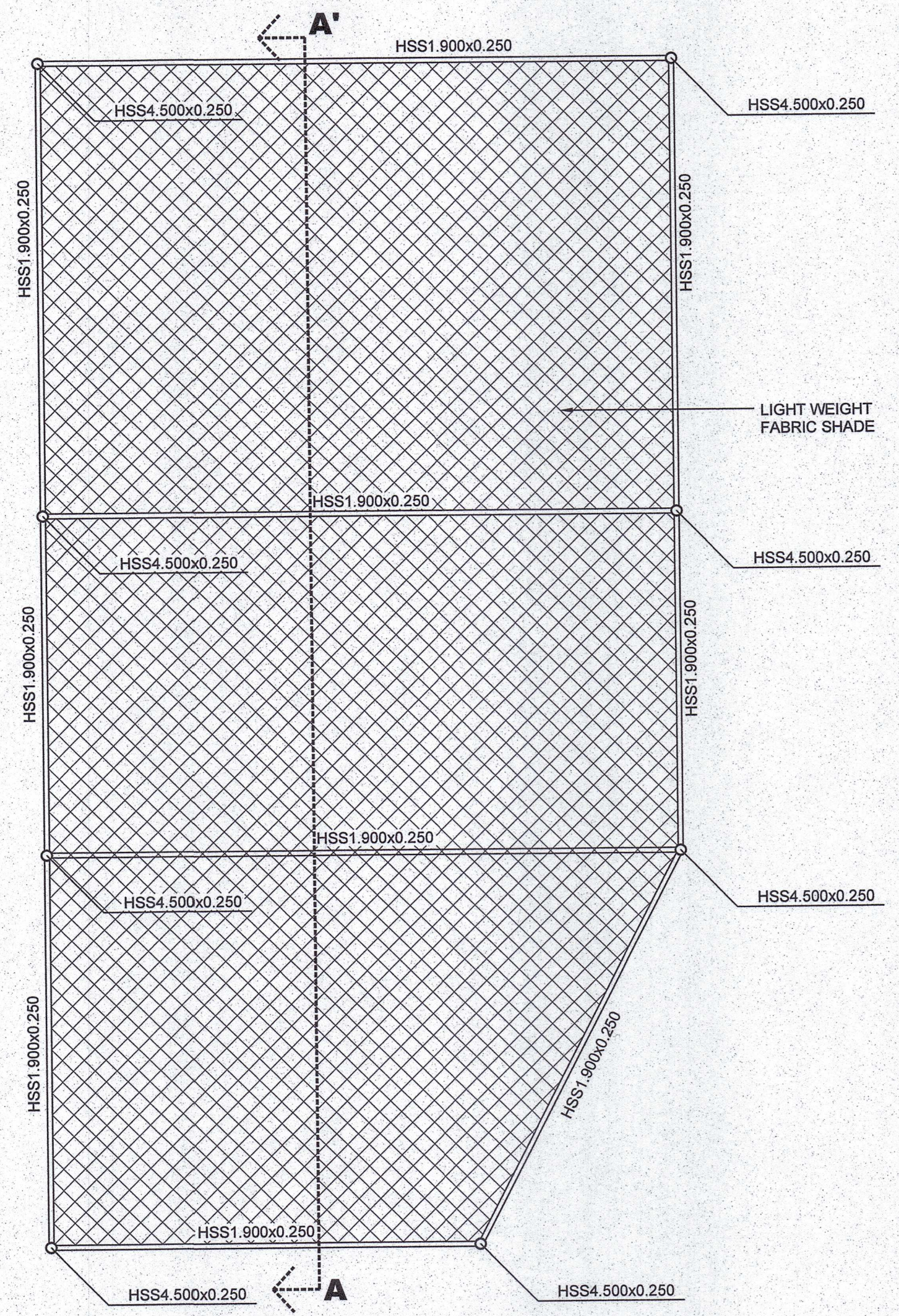

FRAMING PLAN

SCALE 1/4" = 1'-0"

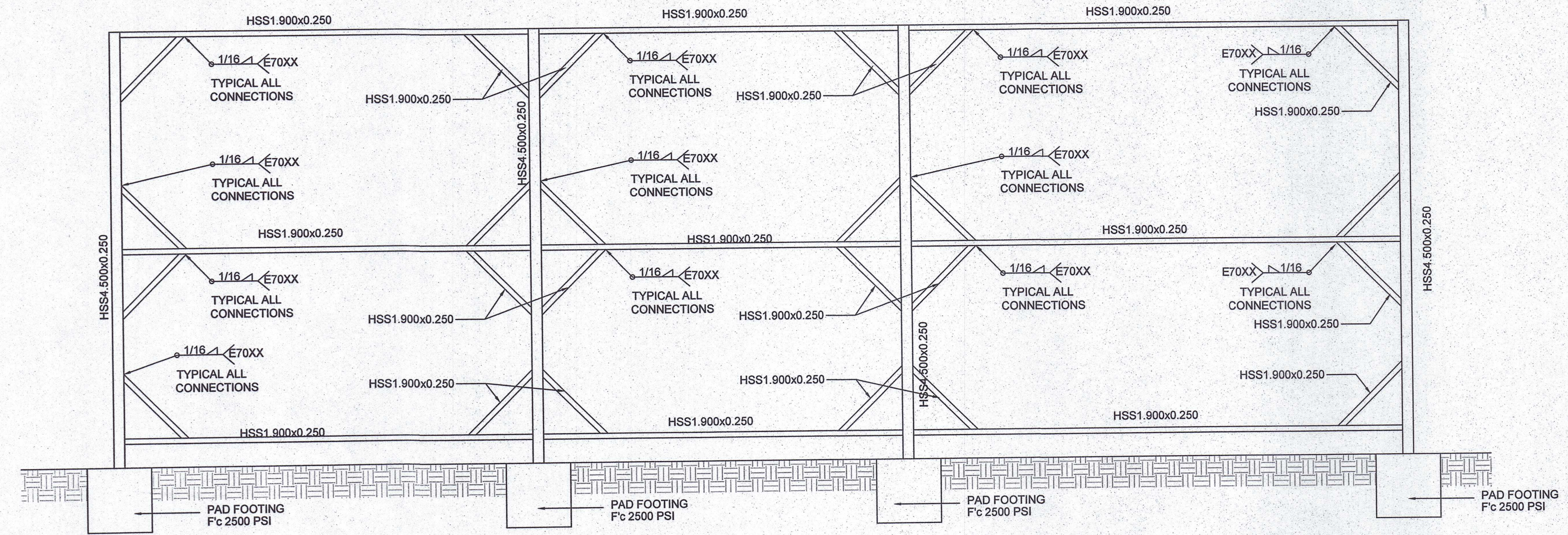

CROSS SECTION PLAN A-A'

SCALE 1/4" = 1'-0"

PROJECT SHALL COMPLY WITH THE FOLLOWING CODES:
2022 CALIFORNIA BUILDING CODE
2021 INTERNATIONAL BUILDING CODE

THE STRUCTURE WILL BE LOCATED ENTIRELY ON NATIVE/UNDISTURBED SOIL.

DESIGN LOADS:	
ROOF DEAD LOAD	1 PSF
ROOF LIVE LOAD	5 PSF

SEISMIC PARAMETERS	
Se	1.598
S1	0.657
SDs	1.065
SD1	0.657
Fa	1.000
Fv	1.500
SITE CLASS	D

WIND	
BASIC WIND SPEED	98 M.P.H.
WIND IMPORTANCE FACTOR	1.00
WIND BUILDING CATEGORY	II
WIND EXPOSURE	C
DESIGN WIND PRESSURE	16 PSF

REINFORCED CONCRETE NOTES:
1.- THE MINIMUM 28-DAY CYLINDER STRENGTH SHALL BE AS FOLLOWS, U.N.O.

CONCRETE ELEMENT	F'c
SLAB ON GRADE	2500 PSI
CONTINUOUS FOOTING	2500 PSI
SPREAD/PAD FOOTINGS	2500 PSI

ALL CONCRETE REQUIRED TO BE MORE THAN 2500 PSI SHALL HAVE SPECIAL INSPECTION PER 2021 IBC 1705.3.

1.1.- PORTLAND CEMENT SHALL CONFORM TO ASTM C 150, TYPE I OR II

STRUCTURAL STEEL NOTES:
2.1 STRUCTURAL STEEL DESIGN, FABRICATION AND ERECTION SHALL CONFORM TO THE LATEST AISC SPECIFICATIONS.

2.2 ALL STRUCTURAL STEEL INCLUDING NUTS, AND BOLTS SHALL BE GALVANIZED COAT.

2.3 MATERIAL SPECIFICATIONS UNLESS NOTED OTHERWISE:
A. STRUCTURAL SHAPES & PLATES-----ASTM A36
B. PIPE COLUMNS-----ASTM A53, GRADE B
C. STEEL TUBES-----ASTM A501
D. HIGH STRENGTH BOLTS-----ASTM A325

2.4 ALL BOLTS SHALL BE 3/4"Ø A325-SC BOLTS, UNLESS NOTED OTHERWISE.

2.5 WELDING OF STRUCTURAL SHAPES AND PLATES SHALL BE IN CONFORMANCE WITH THE LATEST AMERICAN WELDING SOCIETY SPECIFICATION D1.1.

2.6 ALL WELDING SHALL BE PERFORMED BY LICENSED WELDERS.

THE ENGINEER SHALL NOT BE RESPONSIBLE FOR CONSTRUCTION MEANS, METHODS, TECHNIQUES, SEQUENCES, PROCEDURES OR FOR SAFETY PRECAUTIONS AND PROGRAMS OR FOR THE CONTRACTOR'S FAILURE TO PERFORM THE WORK IN ACCORDANCE WITH THE CONTRACT DOCUMENTS.

THESE DRAWINGS ARE NOT TO BE SCALED FOR DIMENSIONAL INFORMATION. ACTUAL DIMENSION NUMBERS SHOWN ON THE PLANS ARE TO BE USED. IF DIMENSIONAL CONFLICTS EXIST, NOTIFY THE ENGINEER IMMEDIATELY. ANY CONTRACTOR SCALING DRAWINGS FOR ANY PURPOSE DOES SO AT HIS OWN RISK AND IS RESPONSIBLE FOR ANY ERRORS AND MISTAKES WHICH MAY RESULT.

THE FABRIC PROVIDED BY OTHER SHALL SHALL BE TREATED WITH FLAME-RETARDANT MATERIAL REGISTERED AND APPROVED BY THE STATE OF CALIFORNIA FIRE MARSHALL. THE ARTICLE MEETS THE NFPA-701-2010 FLAME RETARDANT STANDARD.

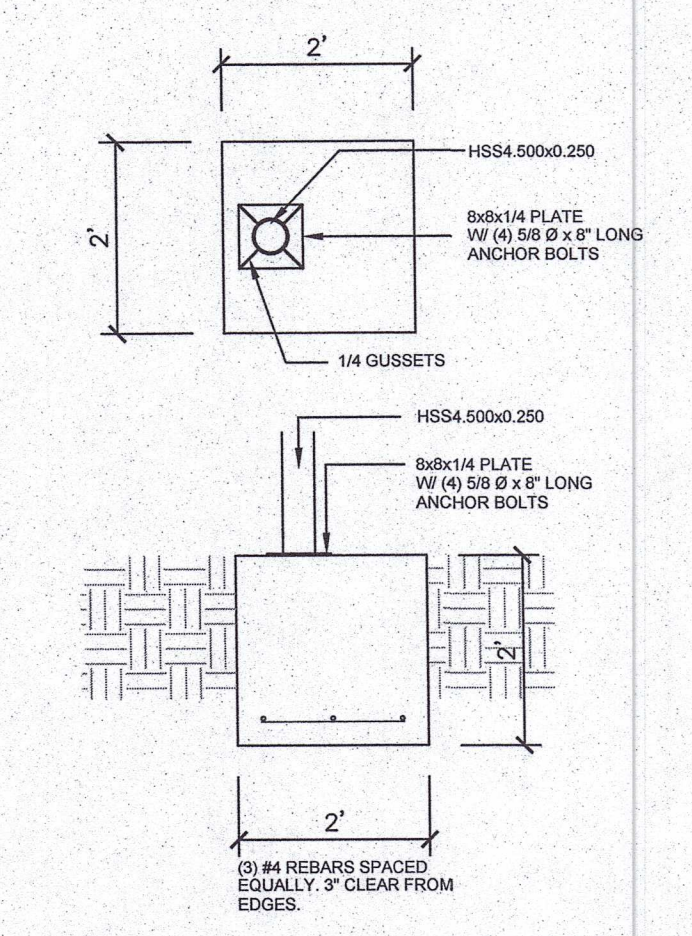

1

SCALE 1/2" = 1'-0"

DRAWING STATUS:
 PRELIMINARY DRAWINGS
 PROGRESS DRAWINGS
 PLAN CHECK/PERMIT DRAWINGS
 CONSTRUCTION DOCUMENTS

CALL BEFORE UNDERGROUND SERVICE ALERT
CALL: TOLL FREE 1-800-422-4133
YOU DIG TWO WORKING DAYS BEFORE YOU DIG



PREPARED UNDER THE DIRECTION OF:
VICTOR RODRIGUEZ-FERNANDEZ
DATE: 10/02/2023

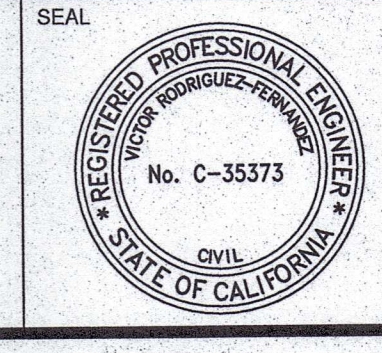

REVISIONS	No.	DESCRIPTION

FABRIC SHADE		SHEET
BY: SCR	PROJECT ADDRESS: 121 N. F ST.	S.1
DATE: 09/27/2023	CLIENT: MARK GADDIS	
JOB NUMBER: 2023-143		

G4 Construction

121 North F Street Imperial, Ca. 92251
(760) 355-4332 – Phone / Fax
mark.gaddis@ymail.com
Lic. #571225

May 29, 2024

Re: Carport located at 121 North F St. Imperial CA, 92251

I met with IID on site and the IID is currently working on a cost sheet. That cost sheet is to route the power lines around the carport since the last power pole on that specific line is just to the south of the carport. By re-routing the wires, the conflict with the IID are then eliminated. I will update the City of Imperial with any new information as soon as it is available.

Mark Gaddis

ATTACHMENT G

NOTE: BY REMOVING THE OVERHEAD POWER LINES FROM POLE #1 (6372) TO POLE #3 (6373) AND THE RECORDATION OF RIGHT-OF-WAY/EASEMENT, THIS WILL ELIMINATE THE SHADE STRUCTURE "REGULATION 23" AND DISTRIBUTION LINE CLEARANCE INFRACTIONS.

CONDUCTOR NOTES:

A	REMOVE EXISTING OVERHEAD CONDUCTOR
B	INSTALL OVERHEAD CONDUCTORS
C	EXISTING CONDUCTORS TO BE RELCOATED

EQUIPMENT NOTES:

1	#6372	EXISTING POLE TO REMAIN
2	#62349	REMOVE COMPLETE
3	#6373	POLE TO BE REPLACED FOR A NEW POLE

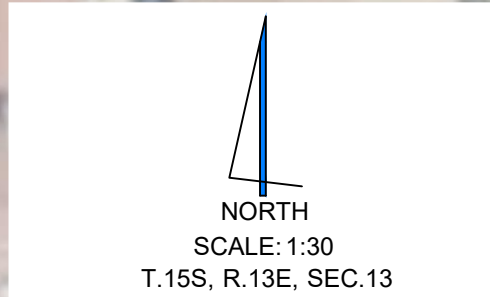
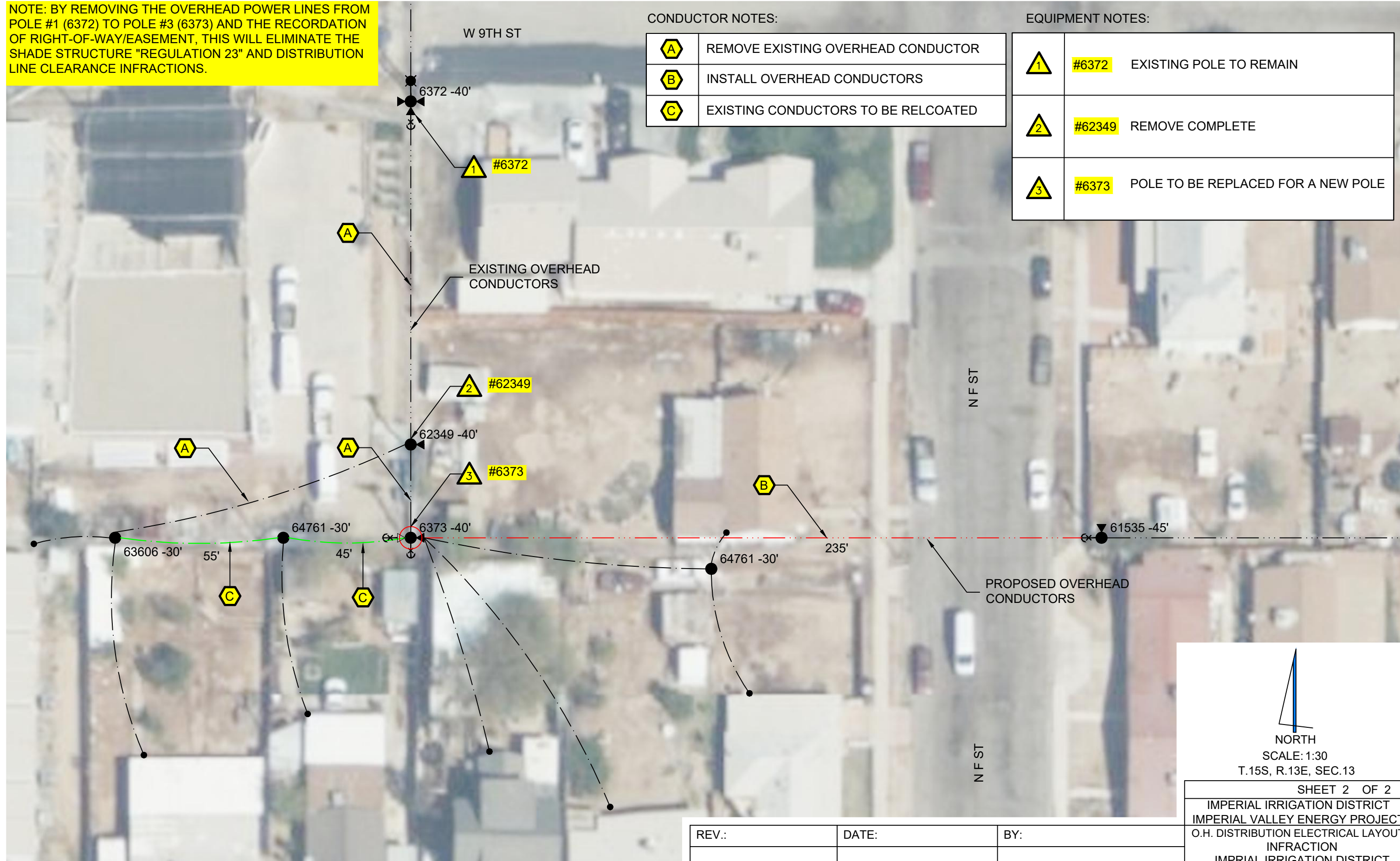

SHEET 2 OF 2	
IMPERIAL IRRIGATION DISTRICT IMPERIAL VALLEY ENERGY PROJECT O.H. DISTRIBUTION ELECTRICAL LAYOUT INFRACTION IMPRIAL IRRIGATION DISTRICT	
CKT: M-321	DATE: 06/18/2024

REV.:	DATE:	BY:	
SERV. NOTIF.: N/A	SERV. ORDER: N/A	SUB: NEW IMPERIAL	

DESIGNED: L. FLORES DRAWN BY: L. FLORES FILE NAME: N/A

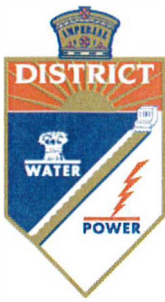

11D

A century of service.

June 17, 2024,

Mr. Mark Gaddis
121 North F Street
Imperial CA, 92251

Re: Construction estimate to relocate overhead power line at 121 North F St. Imperial CA, 92251

Construction Estimate:

• Engineering:	\$ 2,635.05
• Tree Trimming:	\$5,000.00
• Traffic Control:	\$7,500.00
• Construction Labor:	\$37,737.50
• Transportation:	\$5,469.00
• Materials:	\$ 5,802.68
• Service Department:	\$1,989.50
• G&A Overhead:	\$17,686.83
Total:	\$83,820.56

ATTACHMENT I

From: [Nancy Murrieta](#)
To: [Yvonne Cordero](#)
Cc: [Othon Mora](#)
Subject: Re: IID Carport - 121 N. F St.
Date: Wednesday, June 19, 2024 10:23:15 AM
Attachments: [image001.png](#)
[image003.png](#)
[IIDLogo101x66px_201f6792-295d-4c4c-b1c9-296072e9e4cf.png](#)

CAUTION: This email originated from outside the City of Imperial. Do not click links or open attachments unless you recognize the sender and know the content is safe.

Good morning Yvonne,

Mr. Gaddis plans on moving forward with the IID's proposition however Mr. Gaddis is currently out of town and won't be back until September. Therefore he would like to request a continuance on this matter. Can you please advise on the best way to move this continuance forward? Thank you.

Respectfully,

Nancy Murrieta
Office Manager
G/4 Construction
121 North F Street
Imperial, CA 92251
760-355-4332 Office
760-457-5310 Cell

On Tuesday, June 18, 2024 at 02:14:07 PM PDT, Yvonne Cordero <ycordero@cityofimperial.org> wrote:

Good Afternoon Mr. Gaddis and Nancy,

We have reviewed your proposed project with IID that will eliminate the infractions. Please advise as to how you plan on proceeding with this project to include the pertinent information and recommendations in my staff report and formulate the appropriate resolutions.

Also, your project's final decision will be discussed at the next continued public hearing scheduled for June 26, 2024. It is in your best interest that you are in attendance to provide any additional information and answer any of the Commissioner's questions.

Thank you,