



Staff Report

Agenda Item No. D-1

To: City of Imperial Planning Commission

From: Lisa Tylanda, Planner

Date: January 24, 2018

Subject: Conditional Use Permit Request- CUP 18-01 and CUP 18-02
473 & 467 Aten Road; Imperial, CA 92251

Summary:

Applicant:	James Tucker and Joe Heger
Project Location:	473 & 467 Aten Road; Imperial, CA 92251
Zoning:	C-1 Zone
General Plan:	Commercial Neighborhood
Environmental:	Does not initiate CEQA
Recommendation:	Approve Similar Land Use Determination and Conditional Use Permit

Background/Discussion:

The applicants, James Tucker and Joe Heger, have applied for a Conditional Use Permit/Similar Land Use Determination in order to allow for an "RV Storage" Business/Usage located at 467 & 473 Aten Road ; Imperial, CA 92251. The subject site is currently zoned C-1. This zone is intended for professional, administrative offices, restaurant, theatre, health clubs, and for neighborhood shopping centers which provide limited retail business service and office facilities for the convenience of residents of the neighborhood. These stopping centers are intended to be compatible with residential environment as at locations indicated on the General Plan.

Evaluation

The Zoning Ordinance provides flexibility in the regulation of uses to ensure that unusual characteristics of certain uses are properly addressed in furtherance of the Imperial Zoning Ordinance. Section 24.19.340 of the City of Imperial Zoning Ordinance requires that the Commission make specific findings be made when reviewing a CUP. The required findings are listed below in *bold italics*, followed by an evaluation.

1. *That the proposed location, size, design, and operating characteristics of the proposed use is in accord with the Title and Purpose of this Ordinance, the Purpose of the zone in which the site is located, the Imperial General Plan, and the development policies and standard of the City.*

The subject property is in character with the C-1 zone in which it is located. With the recommended Conditions of Approval, the project will be compatible with the neighboring uses. The General Plan Land Use Element encourages (C-1) service-oriented commercial uses to be located near or adjacent to residential uses.

2. *That the location, size, design, and operating characteristics of the proposed use will be compatible with and will not adversely affect or be materially detrimental to adjacent uses, residents, buildings, structures, or natural resources with consideration given to those items listed in Section 24.19.340.B of the Imperial Zoning Ordinance.*

Although the project site is located in an C-1 (Commercial General) zone, the project site is compatible due the similarity of surrounding land uses and will not adversely affect residents.

3. *That the proposed location, size, design, and operating characteristics of the proposed use and the conditions under which it would be operated or maintained will not be detrimental to the public health, safety, or welfare, or materially injurious to properties or improvements in the vicinity.*

The subject property is very limited in nature, and as such, will not be detrimental to the public health, safety, or welfare.

4. *That the proposed Conditional Use will comply with each of the applicable provisions of the Zoning Ordinance, except for any approved Variance.*

The proposed facility shall comply with all provisions of the Zoning Ordinance and Conditions of Approval.

Environmental Compliance

The project is categorically exempt from the California Environmental Quality Act (CEQA) under Section 15300.1 & 15300.2 of the Guidelines.

Recommendation

Staff recommends the Planning Commission conduct a public hearing to receive comments for and against the project. Unless sufficient evidence to the contrary is presented at the public hearing, Staff recommends approval of Conditional Use Permits CUP 18-01 & CUP 18-02 approving a conditional use permit to operate an “RV Storage” business at 467 & 473 Aten Road; Imperial, CA 92251.

Please see attached Exhibit A-Conditions of Approval.

Attachments:

- Resolution No. PC2018-01 & PC18-02 with Conditions of Approval
- Location Map
- Conceptual Site Plan

RESOLUTION PC2018-01

A RESOLUTION OF THE PLANNING COMMISSION OF THE CITY OF IMPERIAL APPROVING A CONDITIONAL USE PERMIT (CUP18-01) FOR RV STORAGE PARKING/YARD AT 467 WEST ATEN BOULEVARD

WHEREAS, James Tucker submitted a Conditional Use Permit applications for an RV Storage and Parking Business at 467 West Aten Boulevard; and

WHEREAS, a duly notified public hearing was held by the Planning Commission during an adjourned meeting on January 24, 2018; and

WHEREAS, upon hearing and considering all testimony and arguments, analyzing the information submitted by staff and considering any written comment received, the Planning Commission considered all facts relating to the request for a Conditional Use Permit.

NOW THEREFORE, BE IT RESOLVED by the Planning Commission of the City of Imperial as follows:

- A) That the foregoing recitations are true and correct; and
- B) The project has been reviewed in accordance with the requirements set forth by the City of Imperial for implementation of the California Environmental Quality Act; and
- C) There are no sensitive resources located within the area of the project or adjacent to the area of the project so as to be significantly impacted by the project; and
- D) That based on the evidence presented at the public hearing, the Planning Commission hereby determines that the project is Categorically Exempt under Section 15300.1 & 15300.2 of the California Environmental Quality Act; and
- E) That the RV storage and equipment rental yard is consistent with those uses allowed in the C-1 Neighborhood Commercial Zone.
- F) That based on the evidence presented at the public hearing, the Planning Commission hereby **APPROVES** Conditional Use Permit # CUP 18-01 for RV Storage and Parking Business at 467 West Aten Road, subject to the conditions of approval outlined in Exhibit A and based on the following findings:

1. That the proposed location, size, design, and operating characteristics of the proposed use is in accord with the Title and Purpose of this Ordinance, the Purpose of the zone in which the site is located, the Imperial General Plan, and the development policies and standard of the City.
2. That the location, size, design, and operating characteristics of the proposed use will be compatible with and will not adversely affect or be materially detrimental to adjacent uses, residents, buildings, structures, or natural resources with consideration given to those items listed in Section 24.19.340.B of the Imperial Zoning Ordinance.
3. That the proposed location, size, design, and operating characteristics of the proposed use and the conditions under which it would be operated or maintained will not be detrimental to the public health, safety, or welfare, or materially injurious to properties or improvements in the vicinity.
4. That the proposed Conditional Use will comply with each of the applicable provisions of the Zoning Ordinance, except for an approved Variance.

PASSED, ADOPTED AND APPROVED by the Planning Commission of the City of Imperial, this 24th day of January 2018.

Planning Commission Chairman

ATTEST:

City Clerk

EXHIBIT A
RESOLUTION PC2018-01
CONDITIONS OF APPROVAL
for
RV Storage/Parking Business
467 West Aten Boulevard

1. The approved project shall consist of an RV Storage/ Parking Business only.
2. There are **not** to be any hook-up or dumping locations on site at the RV Storage/Parking Business.
3. All storage areas shall be screened from public view by utilizing solid fencing throughout the project site.
4. If lighting is to be installed on the project site, the Applicant shall submit a lighting plan prior to any construction activity. All lighting installed shall be shielded and directed so as to minimize significant off-site glare or adverse light intrusion into neighboring properties. The lighting plan shall be reviewed and approved by the City of Imperial Planning Department and Building Department.
5. Landscaping shall be provided in all setback areas and shall be irrigated with an automatic system. Landscaping shall consist of environmental friendly trees, shrubs and groundcover (dimensions are noted in the project design). The applicant has one (1) year to meet the City of Imperial's requirement.
6. Applicant shall comply with all local, State and Federal laws, regulations, rules, ordinances, and standards as they pertain to this project, whether specified herein or not. Where conflicts occur, the most stringent shall apply.
7. The conditional approval of the Conditional Use Permit shall not constitute the waiver of any requirement of the City's Ordinances or regulations, except where a condition set forth herein specifically provides for a waiver.
8. The Applicant shall pay all impact and capacity fees as required by the city.
9. The site shall control dust generation through daily watering in accordance with a dust control plan submitted to and approved by the Air Pollution Control District as required by Imperial APCD.
10. The development shall utilize building construction techniques such as equipment muffles, and noise insulation to reduce the noise impacts to Normally Acceptable Levels as outlined in Figure N-1 of the City of Imperial General Plan Noise Element

11. All applicable Conditions of Approval shall be completed prior to opening for business.
12. The provisions of the permit are to run with the land/project and shall bind the current and future owner(s) successor(s) in interest, assignee(s) and/or transferor(s) of said project.
13. The construction or operation of the RV storage parking/yard shall not add to the contamination of the soil, alter ground water flow, create additional drainage runoff or alter topography in such a way that creates hazards to the proposed site, adjoining properties, or the City.
14. If the Community Development Department finds and determines that the Permittee or successor-in-interest has not complied or cannot comply with the terms and conditions of the CUP, or the Planning/Building Department determines that the permitted activities constitute a nuisance, the City shall provide Permittee with notice and opportunity to comply with the enforcement or abatement order. If after receipt of the order (1) Permittee fails to comply, and/or (2) Permittee cannot comply with the conditions set forth in the CUP, then the matter shall be referred to the Planning Commission for permit modification, suspension, or termination, or to the appropriate enforcement authority.
15. As between the City and the Permittee, any violation of this permit may be a "nuisance per se". The City may enforce the terms and conditions of this permit in accordance with its Codified Ordinances and/or State law. The provisions of this paragraph shall not apply to any claim of nuisance per se brought by a third party.
16. Permittee shall not be permitted to maintain a "nuisance", which is anything which: (1) is injurious to health, or is indecent or offensive to the senses, or an obstruction to the free use of property, so as to interfere with the comfortable enjoyment of life or property, and/or (2) affects at the same time an entire community or neighborhood, or any considerable number of persons, although the extent of the annoyance or damage inflicted upon individuals may be unequal, and/or (3) occurs during or as a result of the approved project.
17. Where a commercial or office use abuts property in any residential zone, a masonry wall six (6) feet in height from the highest finished grade at the property line shall be erected and maintained between such uses and the residential zone. In addition, a five (5) foot landscaped screen or buffer shall be installed and maintained.
18. The noise level emanating from any commercial use or operation shall not exceed five decibels (as defined in the Occupational Safety and Health Act of 1970) above the ambient level of the area measured at the property line.
19. Reciprocal ingress and egress, circulation and parking arrangements shall be required to facilitate the ease of vehicular movement between adjoining properties.

20. Outdoor Storage and/or Sales Areas shall be entirely enclosed by solid masonry walls or opaque fencing, not less than six (6) feet in height to adequately screen the view of outdoor storage areas from view.
21. 10% landscaping required in the front yard of the parcel.

RESOLUTION PC2018-02

A RESOLUTION OF THE PLANNING COMMISSION OF THE CITY OF IMPERIAL APPROVING A CONDITIONAL USE PERMIT (CUP18-02) FOR RV STORAGE PARKING/YARD AT 473 WEST ATEN BOULEVARD

WHEREAS, Joe Heger submitted a Conditional Use Permit applications for an RV Storage and Parking Business at 473 West Aten Boulevard; and

WHEREAS, a duly notified public hearing was held by the Planning Commission during an adjourned meeting on January 24, 2018; and

WHEREAS, upon hearing and considering all testimony and arguments, analyzing the information submitted by staff and considering any written comment received, the Planning Commission considered all facts relating to the request for a Conditional Use Permit.

NOW THEREFORE, BE IT RESOLVED by the Planning Commission of the City of Imperial as follows:

- A) That the foregoing recitations are true and correct; and
- B) The project has been reviewed in accordance with the requirements set forth by the City of Imperial for implementation of the California Environmental Quality Act; and
- C) There are no sensitive resources located within the area of the project or adjacent to the area of the project so as to be significantly impacted by the project; and
- D) That based on the evidence presented at the public hearing, the Planning Commission hereby determines that the project is Categorical Exempt under Section 15300.1 & 15300.2 of the California Environmental Quality Act; and
- E) That the RV storage and equipment rental yard is consistent with those uses allowed in the C-1 Neighborhood Commercial Zone.
- F) That based on the evidence presented at the public hearing, the Planning Commission hereby APPROVES Conditional Use Permit # CUP 18-02 for RV Storage and Parking Business at 473 West Aten Road, subject to the conditions of approval outlined in Exhibit A and based on the following findings:
 - 1. That the proposed location, size, design, and operating characteristics of the proposed use is in accord with the Title and Purpose of this Ordinance, the Purpose of the zone in which the site is located, the Imperial General Plan, and the development policies and standard of the City.

2. That the location, size, design, and operating characteristics of the proposed use will be compatible with and will not adversely affect or be materially detrimental to adjacent uses, residents, buildings, structures, or natural resources with consideration given to those items listed in Section 24.19.340.B of the Imperial Zoning Ordinance.
3. That the proposed location, size, design, and operating characteristics of the proposed use and the conditions under which it would be operated or maintained will not be detrimental to the public health, safety, or welfare, or materially injurious to properties or improvements in the vicinity.
4. That the proposed Conditional Use will comply with each of the applicable provisions of the Zoning Ordinance, except for an approved Variance.

PASSED, ADOPTED AND APPROVED by the Planning Commission of the City of Imperial, this 24th day of January 2018.

Planning Commission Chairman

ATTEST:

City Clerk

EXHIBIT A
RESOLUTION PC2018-02
CONDITIONS OF APPROVAL
for
RV Storage/Parking Business
473 West Aten Boulevard

1. The approved project shall consist of an RV Storage/ Parking Business only.
2. There are not to be any hook-up or dumping locations on site at the RV Storage/Parking Business.
3. All storage areas shall be screened from public view by utilizing solid fencing throughout the project site.
4. If lighting is to be installed on the project site, the Applicant shall submit a lighting plan prior to any construction activity. All lighting installed shall be shielded and directed so as to minimize significant off-site glare or adverse light intrusion into neighboring properties. The lighting plan shall be reviewed and approved by the City of Imperial Planning Department and Building Department.
5. Landscaping shall be provided in all setback areas and shall be irrigated with an automatic system. Landscaping shall consist of environmental friendly trees, shrubs and groundcover (dimensions are noted in the project design). The applicant has one (1) year to meet the City of Imperial's requirement.
6. Applicant shall comply with all local, State and Federal laws, regulations, rules, ordinances, and standards as they pertain to this project, whether specified herein or not. Where conflicts occur, the most stringent shall apply.
7. The conditional approval of the Conditional Use Permit shall not constitute the waiver of any requirement of the City's Ordinances or regulations, except where a condition set forth herein specifically provides for a waiver.
8. The Applicant shall pay all impact and capacity fees as required by the city.
9. The site shall control dust generation through daily watering in accordance with a dust control plan submitted to and approved by the Air Pollution Control District as required by Imperial APCD.
10. The development shall utilize building construction techniques such as equipment muffles, and noise insulation to reduce the noise impacts to Normally Acceptable Levels as outlined in Figure N-1 of the City of Imperial General Plan Noise Element
11. All applicable Conditions of Approval shall be completed prior to opening for business.
12. The provisions of the permit are to run with the land/project and shall bind the current and future owner(s) successor(s) in interest, assignee(s) and/or transferor(s) of said project.
13. The construction or operation of the RV storage parking/yard shall not add to the contamination of the soil, alter ground water flow, create additional drainage runoff or alter topography in such a way that creates hazards to the proposed site, adjoining properties, or the City.

14. If the Community Development Department finds and determines that the Permittee or successor-in-interest has not complied or cannot comply with the terms and conditions of the CUP, or the Planning/Building Department determines that the permitted activities constitute a nuisance, the City shall provide Permittee with notice and opportunity to comply with the enforcement or abatement order. If after receipt of the order (1) Permittee fails to comply, and/or (2) Permittee cannot comply with the conditions set forth in the CUP, then the matter shall be referred to the Planning Commission for permit modification, suspension, or termination, or to the appropriate enforcement authority.

15. As between the City and the Permittee, any violation of this permit may be a "nuisance per se". The City may enforce the terms and conditions of this permit in accordance with its Codified Ordinances and/or State law. The provisions of this paragraph shall not apply to any claim of nuisance per se brought by a third party.

16. Permittee shall not be permitted to maintain a "nuisance", which is anything which: (1) is injurious to health, or is indecent or offensive to the senses, or an obstruction to the free use of property, so as to interfere with the comfortable enjoyment of life or property, and/or (2) affects at the same time an entire community or neighborhood, or any considerable number of persons, although the extent of the annoyance or damage inflicted upon individuals may be unequal, and/or (3) occurs during or as a result of the approved project.

17. Where a commercial or office use abuts property in any residential zone, a masonry wall six (6) feet in height from the highest finished grade at the property line shall be erected and maintained between such uses and the residential zone. In addition, a five (5) foot landscaped screen or buffer shall be installed and maintained.

18. The noise level emanating from any commercial use or operation shall not exceed five decibels (as defined in the Occupational Safety and Health Act of 1970) above the ambient level of the area measured at the property line.

19. Reciprocal ingress and egress, circulation and parking arrangements shall be required to facilitate the ease of vehicular movement between adjoining properties.

20. Outdoor Storage and/or Sales Areas shall be entirely enclosed by solid masonry walls or opaque fencing, not less than six (6) feet in height to adequately screen the view of outdoor storage areas from view.

21. 10% landscaping required in the front yard of the parcel.

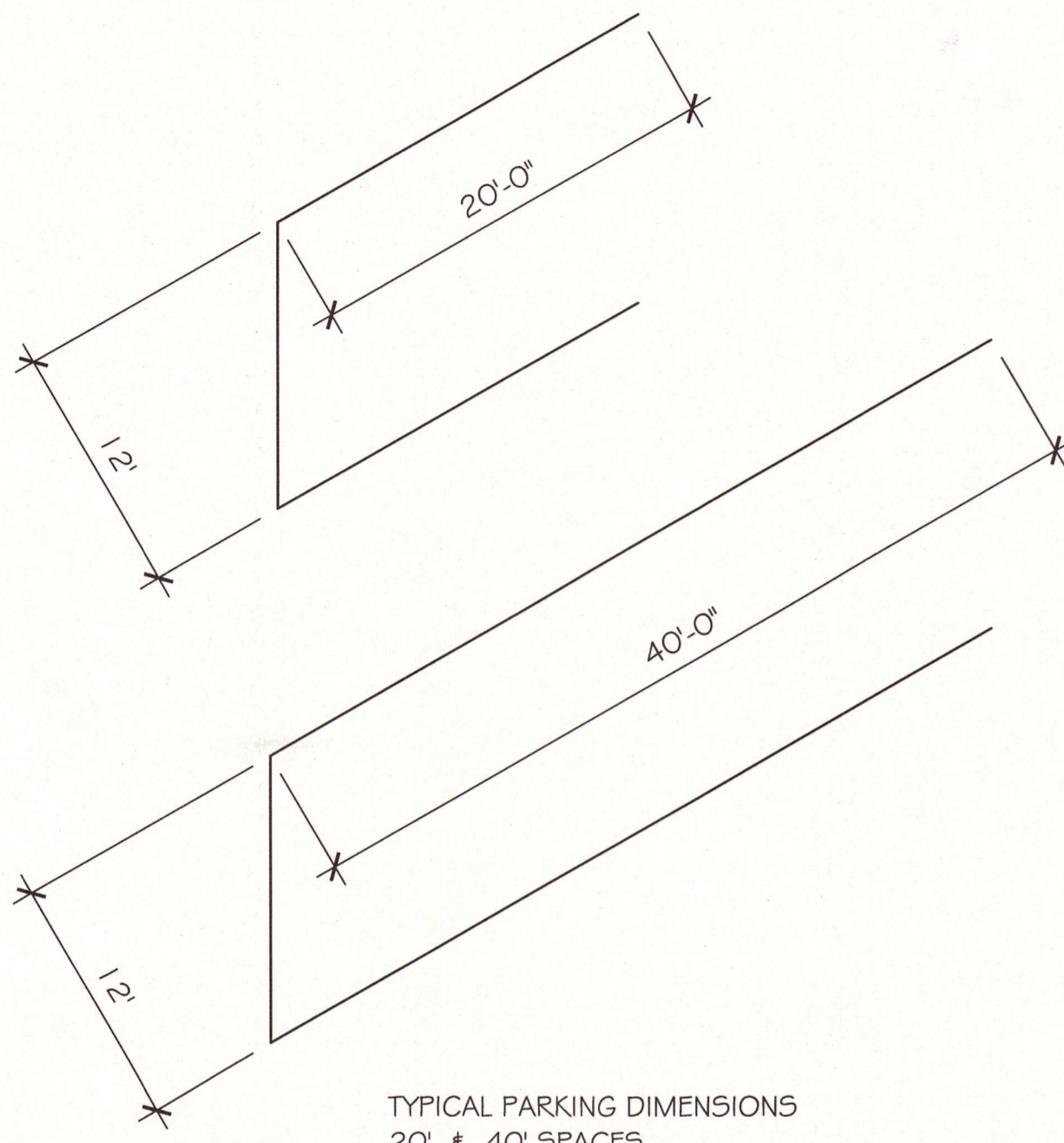

TYPICAL PARKING DIMENSIONS
20' x 40' SPACES
AN APPROVED SURFACE WILL BE INSTALLED
FOR ALL-WEATHER DRIVING CAPABILITIES.

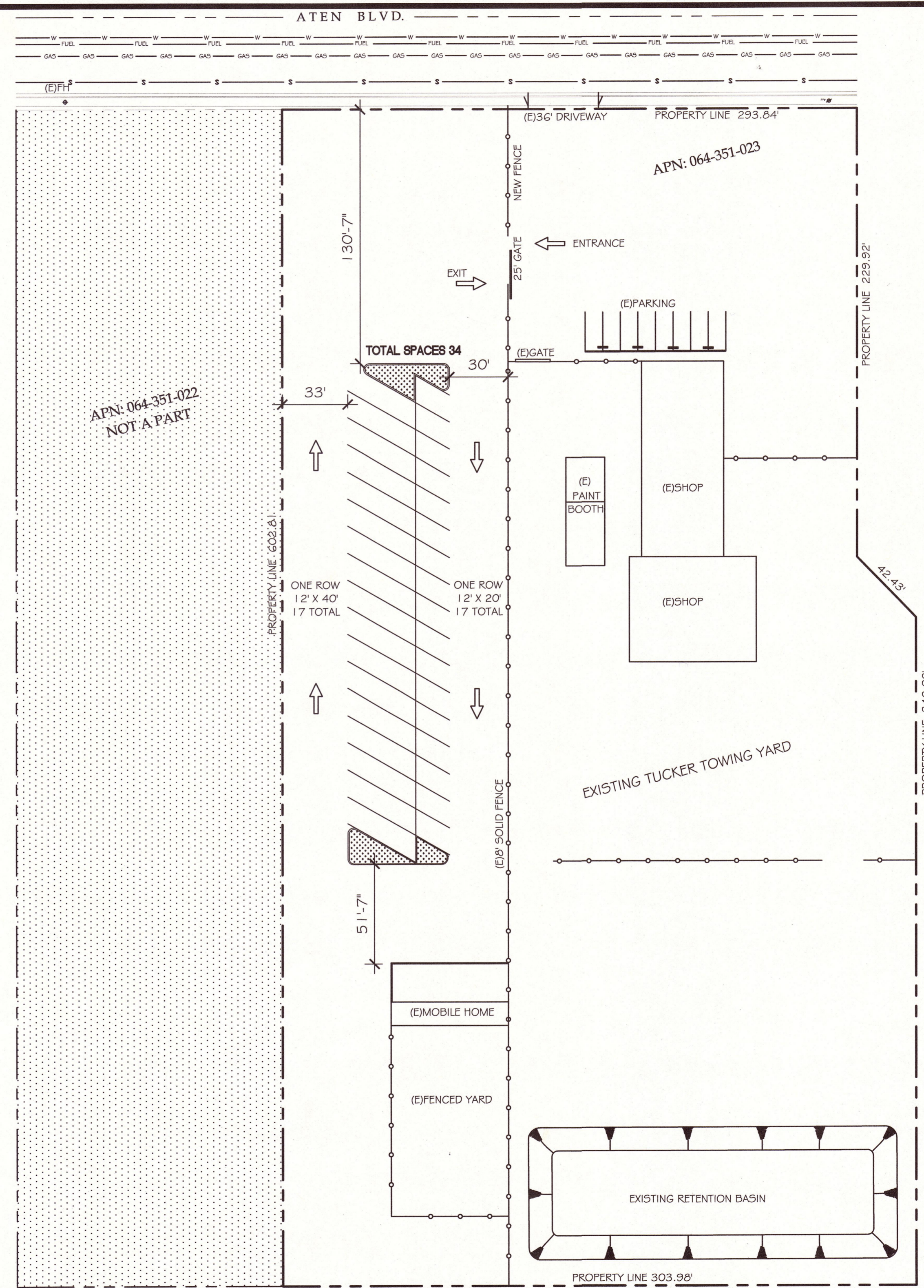

REVISIONS:

1	

JT STORAGE
467 W. ATEN ROAD, IMPERIAL, CA 92251

SHEET TITLE
SITE PLAN

NORTH
SCALE: 1" = 40'-0"

SHEET NUMBER
1

FILE #: QTPLAN-S.dwg
DATE: 01-04-2018

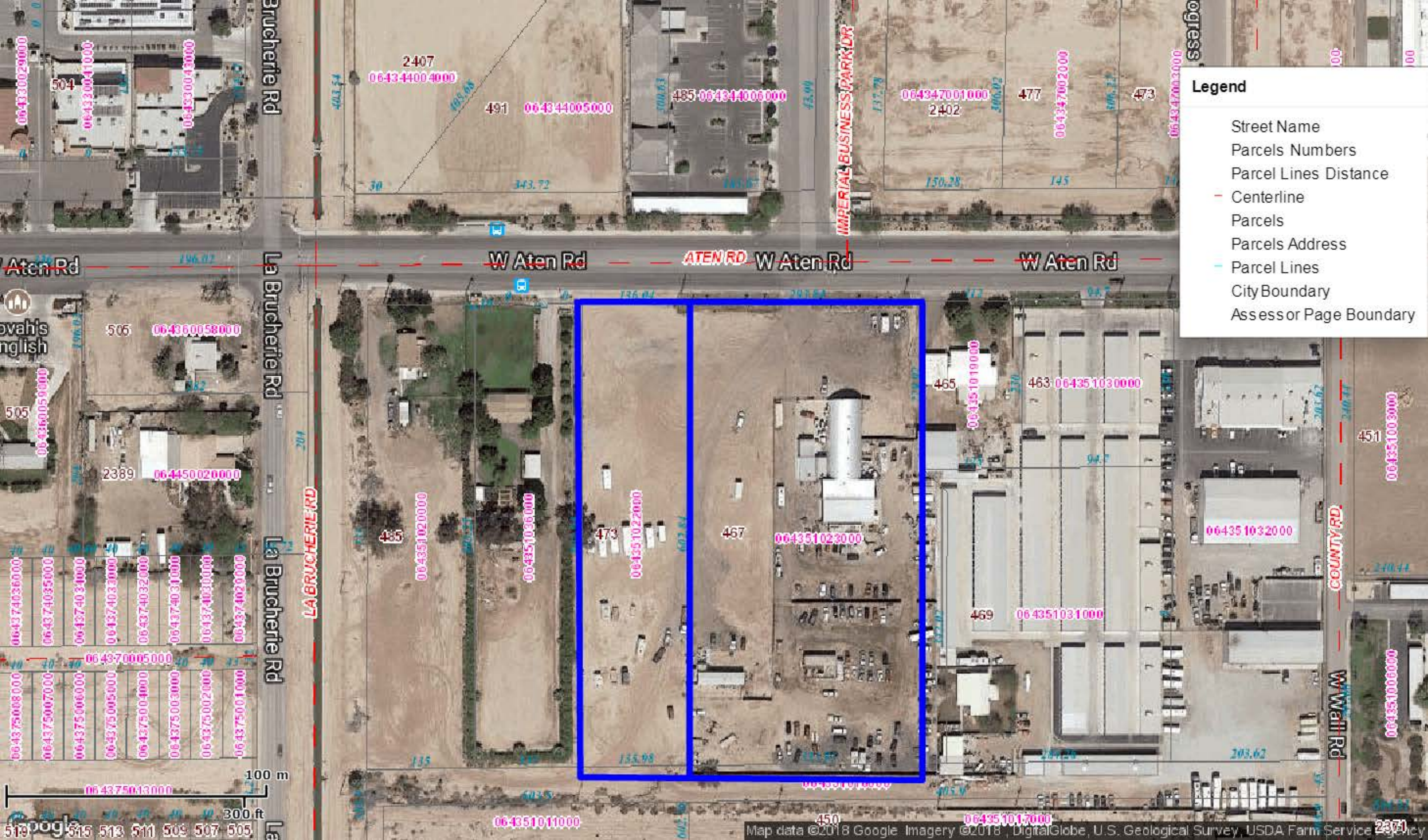

Legend

- Street Name
- Parcels Numbers
- Parcel Lines Distance
- Centerline
- Parcels
- Parcels Address
- Parcel Lines
- City Boundary
- Assessor Page Boundary

100 m
300 ft

Google

519 515 513 511 509 507 505

473 06-435-10-2-2000

467 06-435-10-2-3000

465 06-435-10-1-9000

463 06-435-10-3-0000

469 06-435-10-3-1000

451 06-435-10-3-3000

450 06-435-10-1-7000

2389 06-445-00-2-0000

435 06-435-10-2-0000

436 06-435-10-3-6000

477 06-434-70-0-2000

473 06-434-70-0-3000

2407 06-43-4400-4000

491 06-43-4400-5000

485 06-43-4400-6000

2402 06-434-70-0-1000

504 06-433-00-4-1000

505 06-436-00-5-8000

505 06-436-00-5-9000

505 06-437-40-3-6000

505 06-437-40-3-5000

505 06-437-40-3-4000

505 06-437-40-3-3000

505 06-437-40-3-2000

505 06-437-40-3-1000

505 06-437-50-0-8000

505 06-437-50-0-7000

505 06-437-50-0-6000

505 06-437-50-0-5000

505 06-437-50-0-4000

505 06-437-50-0-3000

505 06-437-50-0-2000

505 06-437-50-0-1000

Brucherie Rd

La Brucherie Rd

LA BRUCHERIE RD

IMPERIAL BUSINESS PARK DR

W Aten Rd

ATEN RD

W Aten Rd

W Aten Rd

COUNTY RD

W Wall Rd